



Jefferson County
Board of Zoning Appeals
Thursday, May 25, 2017, 2:00 p.m.

Members
Tyler Quynn, Chair
Jeffrey Bannon, Vice Chair
Matt Knott
Ted Schiltz
Jeff Bresee
Deirdre Catterton, Alternate

The Jefferson County Board of Zoning Appeals will meet in the Charles Town Library Conference Room located at 200 East Washington Street, at the side entrance pm Samuel Street, in Charles Town, West Virginia. Unless otherwise noted, all requests are pursuant to the Zoning & Land Development Ordinance.

1. Approval of the minutes from the April 27, 2017 meeting.
2. Swearing in of members of the public intending to provide testimony.
3. Variance from Section 9.7 to reduce the side and rear setback from 6' to 1' for a 7' tall fence. Owner: Kathleen A. Holsinger. Location: 50 Garden Place, Charles Town. Tax District: Charles Town (02); Tax Map: 10B; Parcel: 73; Size: .21 ac; Zone: RG; File: ZV17-06.
4. Request for a conditional use permit by Alisha's Child Care to operate a child care facility within an existing home. The facility will provide services for up to 12-children, the existing driveway will be utilized for parking and a 2' x 4' free standing sign will advertise the location. Owner: James Shimp. Location: 130 Maple Ave, Harpers Ferry. Tax District: Harpers Ferry (04); Tax Map: 3A; Parcel: 12; Size: .5 ac; Zone: V; File: CUP17-03.
5. Request for a conditional use permit by Middleway Antique Shop and Information Center for a proposed antique shop and information center to be located in an existing building. The business would utilize an existing gravel parking lot located in the rear of the property and is proposing an 18 sq. ft. sign. Owner: Timothy Johnson. Property location: 7279 Queen St., Kearneysville. Tax District: Middleway (07); Tax Map: 22A; Parcel: 33; Size: .266 ac; Zone: V; File: CUP17-02.
6. Variance from Section 4.10A to waive the requirement of a site plan due to the need for a paved parking lot. Applicant is requesting to utilize the existing gravel parking lot as part of conditional use permit application CUP17-02. Owner: Timothy Johnson. Property location: 7279 Queen St., Kearneysville. Tax District: Middleway (07); Map: 22A; Parcel: 33; Size: .266 ac; Zone: V; File: ZV17-07.
7. Variance from Section 5.7(B)1 to reduce the side setback from 15' to 3' for a 20' x 32' accessory structure. Owner: Suzin & Laurence Wright. Property: 947 Hostler Road, Harpers Ferry. Tax District: Harpers Ferry (04); Tax Map: 15; Parcel: 19.1; Size: 1.18 ac; Zone: R; File: ZV17-09.
8. Zoning Administrator's Report
 - a. Monthly Zoning Certificate Activity Report
9. Legal Update
 - a. Possible executive session on the follow pending lawsuits: None.
 - b. Discussion with possible deliberative session and signing of draft findings/decisions.

Meeting April 27, 2017

 - i. Variance from Section 9.7. Owner: David Young. File: ZV17-04.
 - ii. Request for a CUP for a Popeye's. Owner: Sharp Best & Brown LLC. File: CUP17-01.

Minutes
Jefferson County Board of Zoning Appeals

- 1 Meeting Date: April 27, 2017
- 2 Meeting Location: Charles Town Library Conference Room
3 200 East Washington Street, Charles Town, West Virginia
- 4 Board members present: Tyler Quynn, Chair; Jeffrey Bannon, Vice Chair; Matt Knott, Ted Schiltz,
5 and Jeff Bresee.
- 6 Absent members: Deirdre Catterton, Alternate (with notification)
- 7 Staff members present: Alexandra Beaulieu, Zoning Administrator; Nathan Cochran, Assistant
8 Prosecuting Attorney; and, Jennilee Hartman, Zoning Clerk
- 9 All requests are pursuant to the Jefferson County Zoning and Land Development Ordinance.
- 10 Mr. Schiltz moved to call the meeting to order at 2:00 p.m. The motion carried unanimously.
- 11 Mr. Quynn explained to the public how the meeting would be conducted.
- 12 1. Approval of the March 23, 2017 meeting minutes.
- 13 Mr. Bannon moved to approve the March 23, 2017 minutes with the following edits:
- 14 1) Page 2, line 2, capitalize the Property Safety [Enforcement Agency] Board
- 15 Mr. Quynn called for a vote, which carried unanimously.
- 16 Ms. Beaulieu informed the Board that Ms. Suzin Wright contacted the office requesting that Item #5
17 be withdrawn.
- 18 2. Ms. Hartman swore in members of the public who indicated they would be providing testimony.
- 19 3. Variance request from Section 9.7 to reduce side setback from 8' to 6" for a 28' x 20' deck.
20 Owner: David Young. Location: 62 Briar Patch Lane, Harpers Ferry. District: Harpers Ferry
21 (04); Map: 2; Parcel: 29; Size: 4,592 sf; Zone: R; File: ZV17-04.
- 22 Mr. David Young, applicant, was present to address the Board. Ms. Beaulieu delivered an
23 overview of the staff report and addressed questions from the Board. Ms. Beaulieu explained that
24 as the existing home is a nonconforming structure, it is permitted to expand up to 35% along the
25 subject property line; therefore, the only area that subject to the request is the area shaded peach
26 in the diagram on page 3 of the staff report. This area, which is approximately 71 square feet,
27 exceeds the 35% expansion provision. Mr. Young presented pictures to the Board and addressed
28 their questions. Mr. Quynn opened the public hearing. There was no public comment. Mr. Quynn
29 closed the public hearing.
- 30 Mr. Bresee moved to approve the variance, which carried unanimously.
- 31 4. Request for a conditional use permit for a 3,400 square foot, 60-seat, drive through restaurant
32 (Popeye's) with associated parking and signage. The existing site is to be demolished. Property
33 Owner: Sharp Best & Brown LLC; Jonathon Friedlander, Applicant. Location: 805 E.
34 Washington St. Charles Town. District: Charles Town (02); Map: 8; Parcel: 19; Size: 1.15 ac;
35 Zone: RLIC; File: CUP17-01.
- 36 Mr. Jonathon Friedlander, applicant, and Lisa McCauley, consultant with Allegheny Surveys,
37 were present to address the Board. Ms. Beaulieu provided an overview of the staff report and
38 addressed questions from the Board. Ms. McCauley explained the nature of the request and
39 answered the Board's questions. It was noted that the restaurant would be able to accommodate
40 up to 64 patrons as opposed to 60 stated in the application. When reviewing the details for

1 proposed signage, Ms. McCauley and Mr. Friedlander clarified that they would like to utilize the
2 largest sign detail included in the packet. The Board expressed concern regarding the location of
3 the proposed handicap parking and inquired as to why it was located further away than other
4 parking spaces. The applicant explained that while relocating the handicap spaces would make
5 them physically closer to the building, it would require the disabled person to cross traffic and
6 the drive through stacking lanes. The applicant stated they felt the longer distance was preferable
7 to requiring the disabled person to cross traffic; however, if the Board required the relocation of
8 the handicap spaces, they would make necessary revisions. Mr. Quynn opened the public
9 hearing. Mr. Ronnie Marcus, adjacent property owner, spoke in favor of the request noting that
10 the proposed use would improve the area. Mr. Quynn closed the public hearing.

11 Mr. Bannon motioned to go into deliberative session at 2:45 p.m. Mr. Quynn seconded the
12 motion, which carried unanimously. Mr. Bresee motioned to come out of deliberative session
13 at 3:06 p.m., which carried unanimously.

14 Mr. Knott motioned to approve Conditional Use Permit #CUP17-01, which consists of a
15 3,400 square foot, 64-seat, drive through restaurant (Popeye's) with associated parking and
16 signage with the following conditions:

- 17 a) The applicant/consultant shall reevaluate the proposed handicap parking space location
18 to determine if it is the safest and most efficient location.
- 19 b) The signage will be similar in size (height and width) to the existing signs located on
20 Washington Street.

21 Property Location: 805 E. Washington St. Charles Town. District: Charles Town (02); Map: 8;
22 Parcel: 19; Size: 1.15 ac; Zone: Residential - Light Industrial- Commercial.

23 Mr. Bresee seconded Mr. Knott's motion, which carried unanimously.

24 5. Zoning Administrator's Report

25 a. Monthly Zoning Certificate Activity Report. This report was provided to the Board in the
26 mailed packet.

27 Ms. Beaulieu referred to the list of zoning text amendments that was approved by the
28 County Commission at their March 16, 2017 meeting. The Board requested paper and
29 electronic copies of the changes. Ms. Beaulieu also informed the Board of the status of
30 pending text amendments.

31 6. Legal Update.

- 32 a. Possible executive session on the follow pending lawsuits: None.
- 33 b. Discussion with possible deliberative session and signing of draft findings/decisions.
34 Meeting March 23, 2017
 - 35 i. Variance request from Section 4.18. Owner: Beallair Homes, LLC. File: ZV17-02.
 - 36 ii. Variance request from Section 9.7. Owner: Richard Pauley. File: ZV17-03.

37 Mr. Cochran provided the Board with a draft copy of the Findings for each request.

38 Mr. Knott moved to adjourn the meeting at 3:11 p.m. Mr. Quynn called for a vote, which
39 carried unanimously.

Staff Report
 Jefferson County Board of Zoning Appeals Meeting
 April 27, 2017

Holsinger Variance Request (#ZV17-06)

Item #3 Variance from Sec. 9.7 to reduce the rear setback from 6' to 1' for a 7' tall fence.

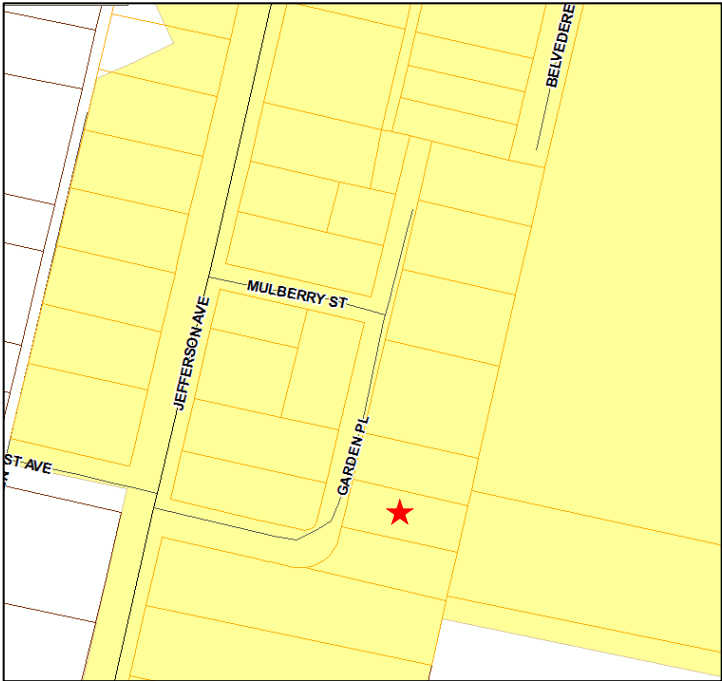
Applicant:	Kathleen A. Holsinger
Owner:	Same as above
Developer:	N/A
Consultant:	N/A
Property Location:	50 Garden Place, Charles Town
Legal Description & Zoning District:	<p style="text-align: center;">District: Charles Town (02) Map: 10B; Parcel: 73 Size: .21 acre; Zone: Residential Growth (RG)</p> 
Surrounding Properties:	Zoning Map Designation: <i>North: RG South: RG</i> <i>East: RG West: RG</i>
History:	N/A
Waivers/Variations:	07-18-1996: Zoning Variance for a reduction of the side setback from 8' to 6' along the northern property boundary to allow for the construction of a carport (ZV96-23, Dodson).
Approved Activity:	Residential

RELEVANT INFORMATION:

1. STAFF EVALUATION OF REQUEST

SUMMARY OF REQUEST AND PURPOSE OF ORDINANCE REQUIREMENTS

The applicant is requesting a variance to reduce the side and rear setback from 6' to 1' to allow for the construction of a 7' tall fence along the rear property line. The applicant currently has a 6' tall fence, which is permitted without obtaining an Improvement Location Permit and is not subject to setback requirements.

Staff Report
Jefferson County Board of Zoning Appeals Meeting
April 27, 2017

Holsinger Variance Request (#ZV17-06)

The Zoning Ordinance and the Improvement Location Permit (ILP) Ordinance both require that fences over 6' in height obtain a permit and comply with building setbacks. Building Code does not come into effect for fences less than 7' in height due to a recent amendment which acknowledged that a standard fence includes 6' panels with posts that are slightly taller than the 6' panels. However, that does not exempt property owners from obtaining an ILP.

The purpose of side and rear yard setback requirements is to reduce the impact that a land use might have on an adjacent property; to allow adequate space between a structure and a property line so that maintenance of the structure is feasible; to maintain adequate separation between structures for fire prevention purposes; and to allow room for utility easements.

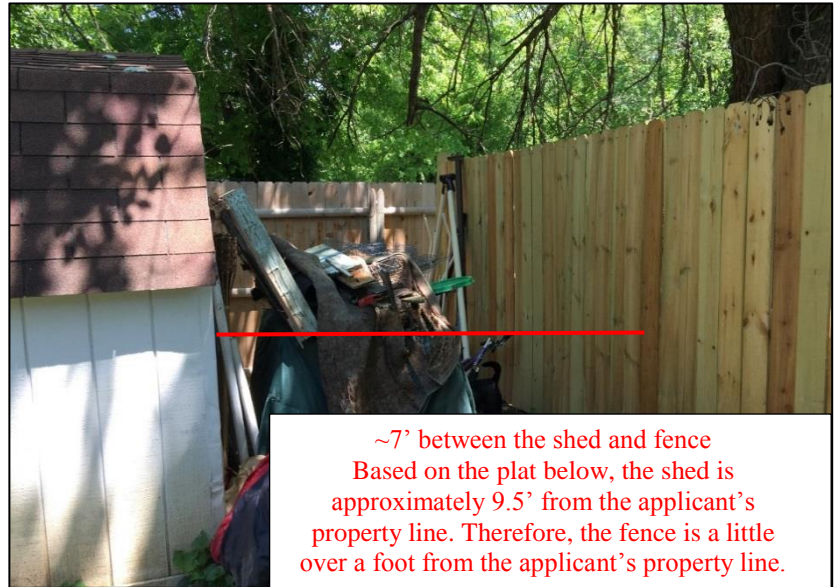

UNIQUE CHARACTERISTICS OF PROPERTY

The subject parcel is Lot 11 in the G.P. Morison Subdivision known as Washington Heights. The Plat was recorded on July 18, 1949.

Below is a survey that was completed for Walter Mills for the proposed Jefferson Heights North subdivision (within City of Charles Town jurisdiction). As part of the survey, the applicant's property is shown (highlighted in yellow) which reflects that the neighbor's property to the south extends along the eastern boundary of the applicant's property, affirming the determination that the eastern boundary line is in fact a rear property line. This information was reviewed with the City of Charles Town's Planner and he agreed with Staff's determination.



Staff Report
Jefferson County Board of Zoning Appeals Meeting
April 27, 2017

Holsinger Variance Request (#ZV17-06)

IMPACT ON ADJACENT PROPERTIES

Since the purpose of the 7' privacy fence is to contain the applicant's dog, it would appear that the proposed fence would benefit the surrounding neighbors.



FEASIBILITY OF COMPLYING WITH THE ORDINANCE BY OTHER MEANS

Based on the dimensions of the property, it appears it is feasible to comply with the setback standards as required by the Zoning Ordinance. However, a 6' fence already exists in the preferred location and as the applicant intends to extend the existing fence to contain her dog in response to neighboring complaints, complying with setback requirements would mean installing an additional fence 5' behind the existing fence, or relocating the existing fence 5' back to comply with the 6' setback.

The exhibit on the left depicts the property and the required setbacks for an accessory structure. The exhibit on the right depicts the applicant's sketch with colored representation.

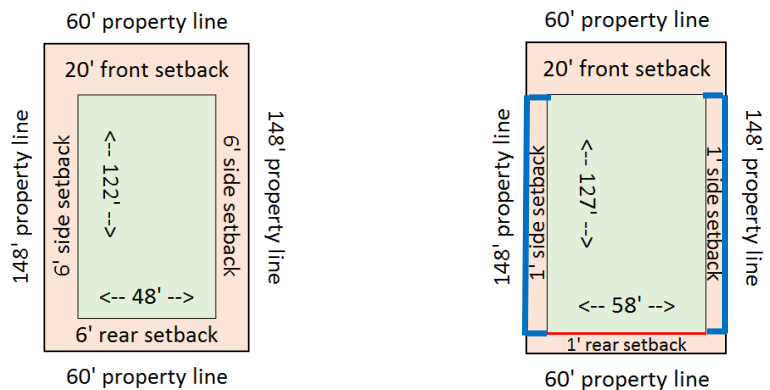

= 7' Fence along Rear Property Line

= 6' or Shorter Existing Fence along property line.

Staff Report
Jefferson County Board of Zoning Appeals Meeting
April 27, 2017

Holsinger Variance Request (#ZV17-06)

CONDITIONS OF APPROVAL

Should the Board choose to approve this request, possible conditions of approval include:

1. The applicant is bound by their testimony and is responsible for ensuring the fence complies with the side and rear setback reduction to 1' as depicted on the sketch in their application.

2. SECTION OF ORDINANCE TO BE CONSIDERED

Section 9.7 Other Exceptions³

For all lots that were approved with setbacks by the Planning Commission as part of the subdivision process prior to September 1, 1989, the setbacks and sizes shall be as established as a part of that process.

Setbacks are as follows in subdivisions for which no setback was stipulated previously by the Jefferson County Planning Commission as a part of the subdivision process:²³

Residential Growth District²³

Single Family Residences

Over 40,000 square feet --	25' front, 12' side and 12' rear
30,000 sq. ft. to 40,000 sq. ft.--	20' front, 10' side and 12' rear
Under 30,000 square feet --	20' front, 8' side and 12' rear

For all lots under 40,000 square feet side and rear setbacks for residential accessory structures shall be 6'.

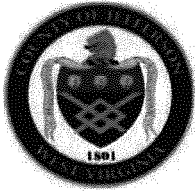

JEFFERSON COUNTY, WEST VIRGINIA
Department of Engineering, Planning, and Zoning
Office of Planning and Zoning
 116 East Washington Street, P.O. Box 338
 Charles Town, WV 25414
 www.jeffersoncountywv.org

File Number: # ZV17-06
 Staff Initials: C/C
 Meeting Date: 4-27-17
 Fees Paid (\$100 or \$150): \$100.00

Email: zoning@jeffersoncountywv.org

Phone: (304) 728-3228

Zoning Variance Request

Variances from the Zoning and Land Development Ordinance must comply with Article 8A-7-11 of the WV State Code. A variance is a deviation from the minimum standards of the ordinance and shall not involve permitting land uses that are otherwise prohibited in the zoning district, nor shall it involve changing the zoning classification of a parcel of land.

Property Owner Information

Name: Kathleen A. Holsinger
 Mailing Address: 50 Garden Place Charles Town WV 25414
 Phone Number: 304-820-7550 Email: kathleen315@msn.com

Applicant Contact Information

Name: Kathleen A. Holsinger
 Mailing Address: _____
 Phone Number: 304 820 7550 Email: kathleen315@msn.com

Applicant Registered Engineer(s), Surveyor(s), or Consultant(s)

Name: _____
 Mailing Address: _____
 Phone Number: _____ Email: _____

Physical Property Details

Physical Address: 50 Garden Place (LT #11 MORISON PLAT) (YEAR BUILT 1990)
 City: Charles Town State: WV Zip Code: 25414
 Tax District: 2nd Map No: 10B Parcel No: 73
 Parcel Size: 1/2 acre 0.207863 Deed Book: 963 Page No: 702

Zoning District (please check one) (LT #11 MORISON PLAT)

Residential Growth (RG)	Industrial Commercial (IC)	Rural (R)	Residential- Light Industrial- Commercial (R-LI-C)	Village (V)	Neighborhood Commercial (NC)	General Commercial (GC)	
<input type="checkbox"/>	<input type="checkbox"/>	<input type="checkbox"/>	<input checked="" type="checkbox"/>	<input type="checkbox"/>	<input type="checkbox"/>	<input type="checkbox"/>	
			Highway Commercial (HC)	Light Industrial (LI)	Major Industrial (MI)	Planned Neighborhood Development (PND)	Office/Commercial Mixed-Use (OC)
			<input type="checkbox"/>	<input type="checkbox"/>	<input type="checkbox"/>	<input type="checkbox"/>	<input type="checkbox"/>

RECEIVED

MAR 31 2017

JEFFERSON COUNTY PLANNING,
 ZONING & ENGINEERING

On a separate sheet of paper, provide a sketch showing the shape and location of the lot indicating all roads, rights of way, and easements. Show the location of the intended construction or land use indicating building setbacks (i.e. the distance of the structure from all property lines), size, and height. Identify all existing buildings, structures, or land uses on the property. The sketch should show the full extent of the property. Sign and date the sketch.

Is there a Code Enforcement action pending in relation to this property? Yes No

Reference the section of the Zoning Ordinance pertaining to this request: 9.7 ft

Briefly describe the nature of the variance request:

Currently there is a 3-4 ft. picket fence along the backside of my property. I am extending it to a 6 ft high fence, however, w/ this variance request, if approved, I would like it to be 7ft high

If this request is for a setback variance, please check one of the following:

Front Setback Side Setback Rear Setback Reduction From 20ft to ~~10ft~~ 6 inches

Please explain why granting the variance will NOT adversely affect the public health, safety or welfare, or the rights of adjacent property owners or residents:

A 7ft high fence will not obstruct the view, the necessary view for pedestrians or vehicles' right of way. The extra foot will be in the form of pickets (shaped, pointed) - Building Permits already allow for 7ft high fences

In what way does this request arise from special conditions or attributes which pertain to the property for which a variance is sought and which were not created by the person seeking the variance?

We have a dog that is a jumper and the pickets discourage my dog from jumping over fence to say "hi" to other people walking their dogs on the back alley. The neighbor behind me has several complaints against my dog running at dog and bite large yard

How will granting this variance eliminate an unnecessary hardship and permit a reasonable use of the land?

This variance, if granted, will put a stop to my dogs being able to easily access my neighbors property, especially when walking their own dogs. They keep escaping my yard

How will granting this variance allow the intent of the Zoning Ordinance to be observed and substantial justice to be done?

The building ordinances already allow for fences that are 7ft high or less w/o a permit being necessary. It would be nice if the zoning ordinance regulations were matched to the 7ft high or less building ordinances

Original signature is required. If additional signatures are necessary, please attach a separate piece of paper.

By signing this application, I give permission for the Office of Planning and Zoning staff to walk onto the subject property, if necessary, in order to take photos for the Board of Zoning Appeals staff reports. The information given is correct to the best of my knowledge.

Kathleen Ambrose 3/31/17
Signature of Property Owner Date

Signature of Property Owner Date

Notification Requirements (to be completed by staff)

Notice of a public hearing for an appeal shall be advertised in a newspaper having general circulation in the County at least 15 days before the hearing. The subject property shall be posted conspicuously by a zoning notice no less than 28" x 22" in size, at least 15 days before the hearing (pursuant to the Zoning and Land Development Ordinance Section 3.4A(3)(b)).

April 27, 2017
Date of Public Hearing

April 12, 2017
Advertising Date

April 12, 2017
Placard Posting Date

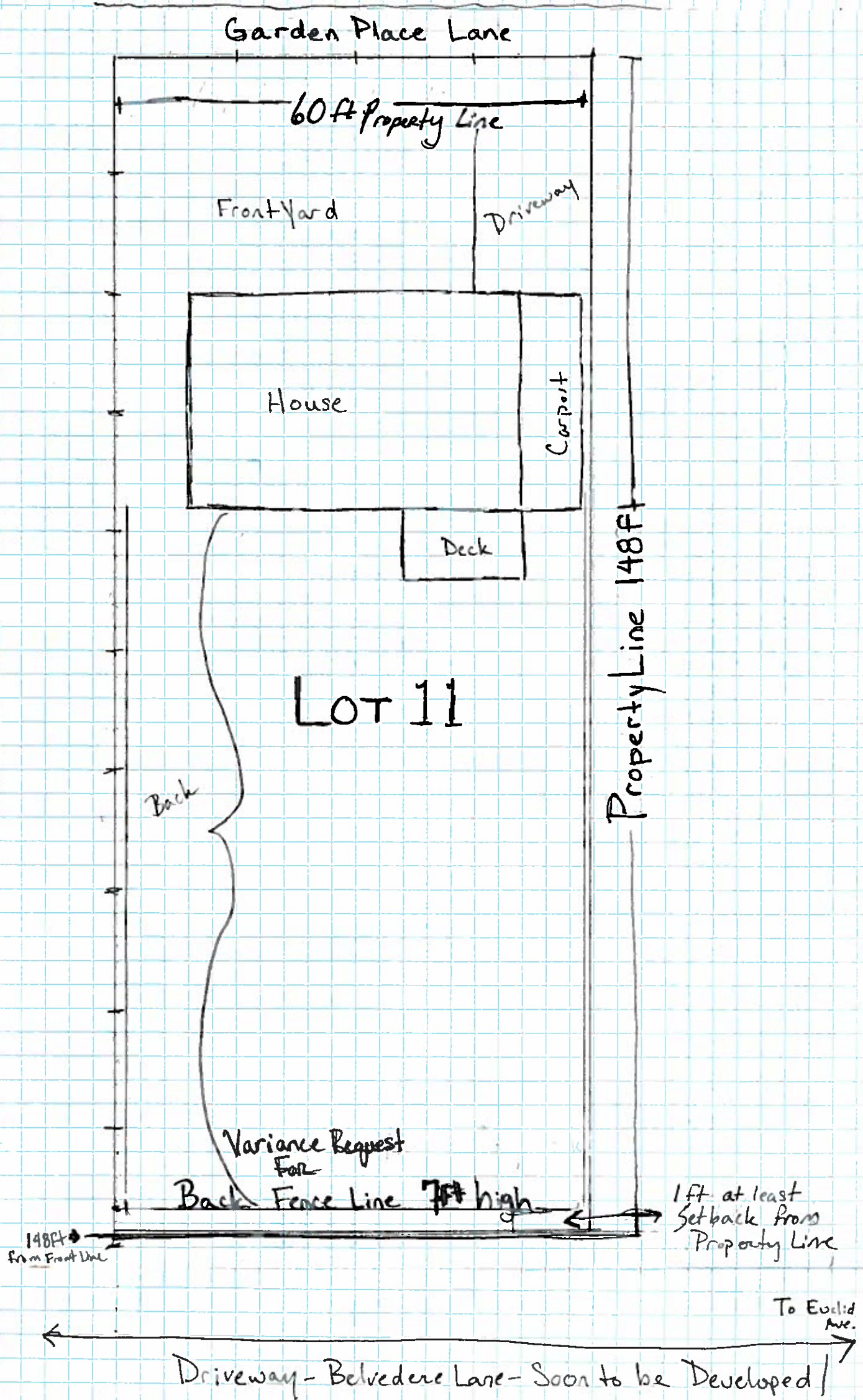

Staff Report
 Jefferson County Board of Zoning Appeals Meeting
 May 25, 2017

**James and Alisha Shimp – In Home Childcare Facility
 Conditional Use Permit Request (#CUP17-03)**

Item #4 Request for a Conditional Use Permit to continue operating a childcare facility within an existing home. The facility provides services for up to 12 children. The existing driveway will be utilized for parking and a 2' x 4' free standing sign advertises the location.

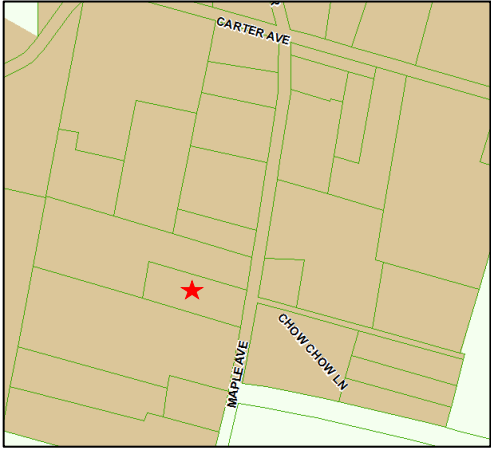
Applicant:	James and Alicia Shimp on behalf of "Alicia's Child Care"
Owner:	James Shimp
Developer:	N/A
Consultant:	Paul Raco, P.J. Raco, Consulting, LLC
Property Location:	130 Maple Avenue, Harpers Ferry (Bakerton)
Legal Description & Zoning District:	District: Harpers Ferry (04); Map: 3A; Parcel: 12 Size: .50 ac; Zone: V 
Surrounding Properties:	Zoning Map Designation: North: Village South: Village East: Village West: Village
History:	Existing Single-Family Home
Waivers/Variations:	None

STAFF EVALUATION OF REQUEST

Summary of Request and Purpose of Ordinance Requirements

The applicant is requesting a Conditional Use Permit to continue their operation of an in-home childcare facility with an enrollment capacity of up to 12 children. Additionally, the applicant is proposing to utilize the existing driveway for parking and a 2' x 4' freestanding sign to identify the property.

Appendix C lists Daycare Center, Large as a Conditional Use in the Village zoning district.

Section 10.4E requires "All signs accessory to a land use subject to the approval of a Conditional Use Permit shall be proposed within the Conditional Use Permit application and assessed by the Board of Zoning Appeals at the required Public Hearing. Such signs shall be maintained at least 1,000 feet between signs. Consideration of the placement of such signs with less than 1,000 foot intervals shall be determined by the Commercial or Residential Uses adjacent to the subject site. Commercial uses adjacent to the subject site may allow spacing intervals of 300 feet. Any variance from this standard shall require consideration and approval by the Board of Zoning Appeals.^{2, 17, 21, 23, 32}"

Staff Report
Jefferson County Board of Zoning Appeals Meeting
May 25, 2017

**James and Alisha Shimp – In Home Childcare Facility
Conditional Use Permit Request (#CUP17-03)**

As there are no other signs in the vicinity of the Shimp’s sign, it appears the applicant meets this criteria.



There is no parking standard established in the Zoning Ordinance for a Daycare Center, Large. Per Article 11 the Zoning Administrator has discretion to establish parking on a case by case basis when parking standards are not established. In referencing the APA Parking Standards, Staff determined that the applicant would need to provide 1 parking space per ten attendees, plus 1 space per employee. Per the applicant’s sketch, there are three parking spaces currently available. Based on these calculations the available parking is sufficient for a facility up to ten attendees.



Property Description

The subject parcel is located on Maple Avenue in a residential neighborhood in Bakerton. The property is zoned Village. The lot is approximately half of an acre, with a large fenced in yard, a paved driveway, and paved parking area, which the applicant has shown to be large enough to accommodate up to three cars.

Staff Report
Jefferson County Board of Zoning Appeals Meeting
May 25, 2017

**James and Alisha Shimp – In Home Childcare Facility
Conditional Use Permit Request (#CUP17-03)**



Impact on adjacent properties

The subject location is situated within a residential neighborhood. Impact on adjacent properties may exist based upon the use generating additional traffic and part of the use expands into the yard (play area). The applicant has installed a fence around the front portion of the property, which may mitigate some of the impact on adjacent properties.

Conditional Use Permit Process

On March 16, 2017 the County Commission adopted a text amendment which eliminated the LESA/ CUP process and replaced with a new CUP Process which requires a public hearing before the Board of Zoning Appeals. Below are the general standards from Section 6.3 of the Zoning Ordinance which the BZA shall consider when reviewing a CUP Application.

“The Board of Zoning Appeals shall have the authority over the issuance or denial of a conditional use permit for uses listed as “Conditional Uses (CU)” in each zoning district. The Board shall have the authority to impose such reasonable conditions and restrictions as are directly related to and incidental to the proposed conditional use permit.”

Staff Report
Jefferson County Board of Zoning Appeals Meeting
May 25, 2017

**James and Alisha Shimp – In Home Childcare Facility
Conditional Use Permit Request (#CUP17-03)**

1. The proposed use is compatible with the goals of the adopted Comprehensive Plan.

The applicant has addressed this criteria in their application.

Staff concurs that the Envision Jefferson 2035 Comprehensive Plan supports redevelopment and expansion of the County’s villages. Bakerton is one of the County’s eight village areas that are currently identified on the County’s zoning map.

2. The proposed use is compatible in intensity and scale with the existing and potential land uses on the adjoining and confronting properties, and poses no threat to public health, safety and welfare.

The applicant has addressed this criteria in their application.

As the primary use will remain residential, the proposed use appears to be compatible in intensity and scale with existing and potential land uses on the adjoining and confronting properties. The applicant has permanent off-street parking available and is not proposing to construct any new structures. The existing sign is modest and blends well with the neighborhood character. In close proximity to the daycare is the Bakerton Post Office, Bakerton Market, a church, and the Bakerton Fire Department (all located on Carter Street).



The proposed use does not appear to pose any threat to public health, safety, and welfare. The applicant has obtained necessary permits and licenses through the State in order to operate a daycare.

3. The proposed site development shall be such that the use will not hinder nor discourage the appropriate development and use of adjacent land and buildings.

The applicant has addressed this criteria in their application.

As the primary use of the property and building is residential, it is anticipated that the daycare would serve the local community and not hinder appropriate development and use of surrounding buildings. As the Comprehensive Plan supports redevelopment and expansion of the County’s Village areas, it would appear that the daycare could be an asset to the community and encourage complementary growth in Bakerton.

Staff Report
Jefferson County Board of Zoning Appeals Meeting
May 25, 2017

**James and Alisha Shimp – In Home Childcare Facility
Conditional Use Permit Request (#CUP17-03)**

- 4. Neighborhood character and surrounding property values shall be safeguarded by requiring implementation of the landscaping buffer requirements found in Appendix B and Section 4.11 of this Ordinance.**

While the existing site would likely be unable to accommodate the typical landscaping requirements found in Section 4.11 and Appendix B, the Board has the discretion to apply this standard or a variation of this standard as they deem fit. Section 4.11 allows for opaque fencing in lieu of landscaping.

As noted in the Applicant's request, Staff determined that for existing structures on lots in the Village district, additional distance requirements and buffers as typically required for commercial uses do not apply based on the reduced side and rear setback standard to 6'. Lots in the village district are typically smaller in size and therefore, unable to accommodate many of the standards for a commercial use. However, it is clear that both the Comprehensive Plan and the Zoning Ordinance support some commercial development within the Village district. For any use listed as a Conditional Use in Appendix C, the Board has the discretion to evaluate the proposed use while considering the character of the area.

- 5. Commercial and Industrial Uses shall be in conformance with Section 8.9 of this Ordinance.**

As part of the Conditional Use Permit application, the applicant was informed of this criteria and shall comply with this standard.



JEFFERSON COUNTY, WEST VIRGINIA
Department of Engineering, Planning and Zoning
Office of Planning and Zoning
 116 East Washington Street, 2nd Floor
 P.O. Box 716
 Charles Town, West Virginia 25414

File #: CUP 17-03
 Mtg. Date: 1/1
 Fee Paid: \$ 300.00
 Staff Int.: _____

Email: zoning@jeffersoncountywv.org

Phone: (304) 728-3228
 Fax: (304) 728-8126

Application for a Conditional Use Permit

Conditional Use Permit process is outlined in Article 6 of the Zoning Ordinance

Project Name

Alisha's Child Care

Property Owner Information

Name: James Shimp, Jr.
 Business Name: _____
 Mailing Address: 130 Maple Avenue, Harpers Ferry, WV 25425 Mail Yes
 Phone Number: 304/876-3364 Email Response: alisha.souders@gmail.com Response: No

Applicant Information

Name: James and Alisha Shimp
 Business Name: Alisha's Child Care
 Mailing Address: 130 Maple Avenue, Harpers Ferry, WV 25425 Mail Yes
 Phone Number: 304/876-3364 Email Response: _____ Response: No

Engineer(s), Surveyor(s), or Consultant(s) Information

Name: Paul J Raco
 Business Name: P. J. Raco Consulting, LLC
 Mailing Address: P.O. Box 548, Charles Town, WV 25414 Mail Yes
 Phone Number: 304/676-8256 Email Response: pjraco.consulting@gmail.com Response: No

Physical Property Details

Physical Address: 130 Maple Avenue (Bakerton), Harpers Ferry, WV 25425
 Tax District: Harpers Ferry Map No: 3A Parcel No. 12
 Parcel Size: Approx 0.5 +- ac 88' x 234' Deed Book: 1163 Page No: 319

Zoning District (please check one)

Residential Growth (RG) <input type="checkbox"/>	Industrial Commercial (I-C) <input type="checkbox"/>	Rural* (R) <input type="checkbox"/>	Residential-Light Industrial-Commercial (R-LI-C) <input type="checkbox"/>	Village (V) <input checked="" type="checkbox"/>	Neighborhood Commercial (NC) <input type="checkbox"/>
General Commercial (GC) <input type="checkbox"/>	Highway Commercial (HC) <input type="checkbox"/>	Light Industrial (LI) <input type="checkbox"/>	Major Industrial (MI) <input type="checkbox"/>	Planned Neighborhood Development (PND) <input type="checkbox"/>	Office/Commercial Mixed-Use (OC) <input type="checkbox"/>

* For properties in the Rural Zoning District:
 Is property located on a primary or secondary road? Yes No

Name of Road and/or Route Number: N/A

RECEIVED
 APR 21 2017
 JEFFERSON COUNTY, WEST VIRGINIA
 DEPARTMENT OF ENGINEERING, PLANNING,
 ZONING & ENGINEERING

Conditional Use Permit Application
Alisha's Child Care
James, Jr. and Alisha Shimp
130 Maple Avenue (Bakerton)
Harpers Ferry, WV 25425
April 19, 2017

Brief Narrative on Proposed Project:

The Applicant and Owner of the property wish to continue their operation of a State Sponsored Childcare in their home in Bakerton. The Applicant has been caring for children for several years; however, only recently at this location. The home will only serve up to 12 children. The facility has already received the WV Fire Marshall approval and has already passed the associated inspections. As required by law, these inspections will continue to ensure that the operation remains in good standing. The facility and Applicant has already received the approval and licensing of the State and the Department of Health and Human Resources (DHHR).

The location is ideal for a childcare operation as it provides a large fenced yard. It is also located in a needed area, most appropriately, the Village of Bakerton. The facility is mostly used by the area residents. It is a sorely needed facility in the area and most of the families that use the facility qualify for State aid for the childcare.

When the Village Districts were created in Jefferson County as a part of the Zoning Ordinance, the intent was to allow existing homes and structures to be used for multiple purposes. Additionally, the County wanted to recognize the historic communities around Jefferson County to allow them to become self-sufficient so that the residents didn't need to travel into the five municipalities for their basic services. What could be more basic than a daycare in a village. This allows the residents to use a close facility that they feel is a part of their own community, without the need to drive for miles to drop the children off and pick them up at the end of the day. Here, some of the families walk the children to the facility before their day begins. It is a most basic convenience in the current times. It isn't really a cliché to say that 'It takes a village' to raise a child. In this case, it is appropriate that the children are cared for by neighbors in their own community.

Conversion of existing structures in Villages do not need to conform to any buffering or landscaping requirements and most setbacks. The Applicant's house meets those setback requirements as determined by the Zoning Administrator. The existing facility is also in compliance with the parking needs for dropping off and picking up the children. The house is served by an existing driveway and will utilize an existing off-street area for parking in the rear that has enough spaces per the requirements of the zoning ordinance. Likewise, the parking has been accepted by the Zoning Administrator.

The Zoning Ordinance has just recently been amended to make it easier for the Board to grant Conditional Uses for uses that make sense in the rural areas in the County, especially villages. This proposal meets that intent and is both compatible with the Comprehensive Plan and the neighborhood. Accordingly, the Board's approval would be greatly appreciated.

The proposal will include an existing sign as shown in the included picture.

Conditional Use Permit Application
Alisha's Child Care
James, Jr. and Alisha Shimp
130 Maple Avenue (Bakerton)
Harpers Ferry, WV 25425
April 19, 2017

Conditional Use Criteria:

1. The proposed use is compatible with the goals of the adopted Comprehensive Plan:

A proposed Childcare use within an existing house and historic district is compatible with the Comprehensive Plan. Throughout the plan, it endorses the use of existing structures and the enhancement of services in the various Villages in the County.

Page 23 of the Comprehensive Plan recognizes Villages as Mixed-Use Communities:

Villages

In addition to the PGAs listed above, the Comprehensive Plan acknowledges the potential provision of water and sewer services, as well as other shared infrastructure, that could lead to the revitalization of the County's villages and **the restoration of the village centers as distinct, mixed-use communities.**" (Emphasis Added)

Bakerton is one of the recognized eight Villages in Jefferson County. Again, the purpose of the Village District was to allow almost a zoning overlay to the area to allow them to be able to service themselves as a distinct community. The Comprehensive Plan includes 'Villages' in the Urban Level Development sections of the Ordinance, as well as, in the Rural Land Use narrative.

The Plan lists many recommendations under the **Urban Level Development Recommendations** beginning on Page 30. Some of pertinent ones include:

- "5. Create urban level land uses within the municipalities, UGBs, PGAs, or **Villages** through rezoning that is consistent with the Plan recommendations.
8. Encourage the location of new community public facilities (such as schools, libraries, parks) within Municipalities, UGBs, PGAs, or **Villages**.

These statements in the Plan recognize the need for additional services in the Villages that that serve the individual communities. This allowance is especially welcomed in re-purposed, existing buildings. If Childcare is needed in a small community like Bakerton, most want it to be in an approved setting in a home.

Finally, the first two recommendation under the Village section of the Comprehensive Plan (Page 45) makes it clear that the proposal is consistent with the Plan:

“Village Recommendations (Goal 3)

1. Create village plans for the redevelopment and expansion of the County’s villages through collaboration with key stakeholders.
 - a. Identify opportunities for restoration, rehabilitation and adaptive reuse of structures within village areas.”
2. Provide land use tools that will enable expansion of the villages that will establish a continuation of village form, scale, and design, using design guidelines and/or other applicable architectural and planning methods.
 - a. Encourage development and redevelopment of village based businesses, residential developments, small-scale multi-family housing, and applicable community facilities within designated village areas and in potential village expansion areas.

This proposed addition of child care into this house within the Bakerton Village District totally conforms to these two recommendations in the Comprehensive Plan.

2. *The proposed use is compatible in intensity and scale with the existing and potential land uses on the adjoining and confronting properties, and poses no threat to public health, safety, and welfare:*

The property is located on one of the main streets in Bakerton. The town’s Post Office and store is right down the street from the home. As illustrated in the Plan, the intent of Village Districts is to allow the utilization of existing structures for small scale commercial and service-based uses to revitalize and serve the community. The location of a daycare or childcare use in a mostly rural residential area, is a very appropriate use. This is the type of facility that should not be located in a commercial area or a busy traffic area. This location is ideal for the use to serve the neighborhood. The house and proposed daycare/childcare use is very compatible with the neighborhood. Villages aren’t new subdivision where everyone comes home and goes into their house for the evening. Bakerton is a community where the neighbors know the neighbors and the residents walk around in their community and walk down to the neighborhood store and Post Office. The addition of a Childcare facility will continue that tradition.

Since the structure exists and already has off-street parking, it should not impact the neighboring structures. The Applicant will utilize the existing entrance, parking and septic system. The proposal already has the approvals of the State Fire Marshall’s Office and the State DHHR’s Office, so there will be no impact on the health, safety and welfare of the community. A

Furthermore, this proposal will not impact the intensity of any potential land uses on the neighboring property in any way. As a matter of fact, it will positively impact the neighborhood by providing a small needed service in the neighborhood. Most likely, this will reduce traffic that is needed to take the children to another area of the County for childcare services.

3. *The proposed site development shall be such that the use will not hinder nor discourage the appropriate development and use of adjacent land and buildings:*

This proposal will have a positive impact on the neighborhood. Once one of the close neighbors uses the facility. The house exists, so there will not be any new construction to disturb the neighbors. The use does not require anything of the neighbors that would negatively affect any plans for development on their land. Additionally, the fence, parking area and driveway already exists.

This use should encourage other service based uses in the community of Bakerton as the Envision Jefferson 2035 Comprehensive Plan endorses in all the eight Villages in the County. Hopefully, more properties are permitted to provide these types of services so that residents don't have to constantly travel to Route 340 to utilize basic services and purchase basic products.

4. *Landscaping Buffer:*

This is not applicable in an existing structure that is located in the Village District.

5. *Rural District Roadway Adequacy:*

This is not applicable since this property is not in the Rural District.

#CLIP1703

April 17, 2017

To Whom it May Concern,

What better sound is there other than the joyous sound of a child's laughter? My name is Angela Hough and my daughter Isabella has been attending Alisha's daycare, located in Bakerton, for over a year now.

I can not say enough good things about this facility. It is clean and well organized. The care that is given to my child is top notch. She receives appropriate meals and snacks, adequate care, and is truly loved like a child of their own. The facility also offers many hands on learning and educational activities that I contribute to the advance developmental capabilities.

It is also important that you know wonderful it is to see a fully functional business within the town of Bakerton! I grew up in this town and have been sad to see how the community has started to crumble. With the addition of the fire department and now this daycare it seems this town is starting to turn around and possibly be more appealing to newcomers.

Lastly, I can not forget to mention what incredible individuals Jimmy and Alisha are. Not only are they pillars of the community, they spend their extra time giving back. Alisha closely works with relay for life and Jimmy volunteers his spare time at the local fire department. In my personal opinion what they offer is very difficult to find and rarely replicated. I am happy to say that a business like this exists in my community and recommend them to anyone and everyone I know. A

Sincerely,

Angela M. Hough (304) 279-4620

184 Maple Ave.

HF WU 25425

CUP17-23

My son attends daycare at Alisha's In Home Child Care Facility. I commute to work from Charles Town to DC by riding the Marc Train. I'm new to the area and struggled to find a daycare that was nearby and also had business hours that could accommodate my longer than usual work days. Fortunately a family member from the area found this daycare and both our children now attend this daycare together.

Being that I ride the Marc Train from the train station on Flowing Springs road, the location is very convenient for me. It's not only near the daycare but also near my home. After a long day commuting to work and back, the last thing I want is to have a long drive ahead of me to pick my son up and another long drive home. Being that I commute, our time is already limited during the week so it's nice that we have time to play, relax, have dinner, bathe and get to bed without rushing all thanks to the convenient location.

The hours are also superior to other daycares. Due to commuting to work, my work days are much longer than the average working person. Other daycares in the area are open for a shorter amount of time. Being that I'm a single mom and don't have anyone that can watch my son (or pick him up and drop him off for me) on a regular basis, this daycare has saved my career. If it weren't for this daycare, I would be forced to quit my job and take a lesser paying job. I would have to find a job in the area that fit the other daycare's hours as opposed to this daycare fitting the hours and needs of my family.

An added bonus, as mentioned before, my son's cousin attends the same daycare and has another cousin on the way that will also attend. Family is important; it's great that my son and his cousins get to spend time together each day. I love that they're able to spend so much time together on a regular basis.

I know my child and other children who attend this daycare are well taken care of. Overall, this daycare is a benefit to the community, not only because of its favorable location and hours of operation but also because of the wonderful family that runs the daycare.

Sincerely,

Allyson Stewart

714 Crosswinds Dr.
Charles town WV
25414

~~(525) 993 8460~~
(525) 993 8460

#CUP17 03

To Whom It May Concern:

I am writing this in interest of Alisha's In-Home Childcare Services. I believe it is a great facility to have in the Bakerton area. It is great for parents who commute to Maryland every day. There are not many facilities in Bakerton or Harpers Ferry. The location is great as it only takes me maybe 15 minutes to get to. I know of one in Harpers Ferry but none in Bakerton. Her services are great because she does transportation to Ranson Elementary so I did not have to transfer my children and they get to attend the school they really like. Her hours and flexibility really helps the parents as many people do not get back to town until after six and most places closes at six. Another great service is she accepts Mountain Heart and it's hard to find somebody that could accept 4 children at different ages that have Mountain Heart. I have been to at least four different daycare facilities and none accommodates my needs as much as her services. I have experienced many difficulties at other facilities but none here. My children have been with her for 4 years now and really like her and enjoy being at her facility. Her and her husband are amazing people that really benefit me and my children. I am a single mother of four so her facility is very important for me to have as I do not have much help from my family. If you should have any questions you may contact me at 304-240-4530.

Thank You,

Natalie Parrish

28 Camden Dr.

Charles Town, WV 25414

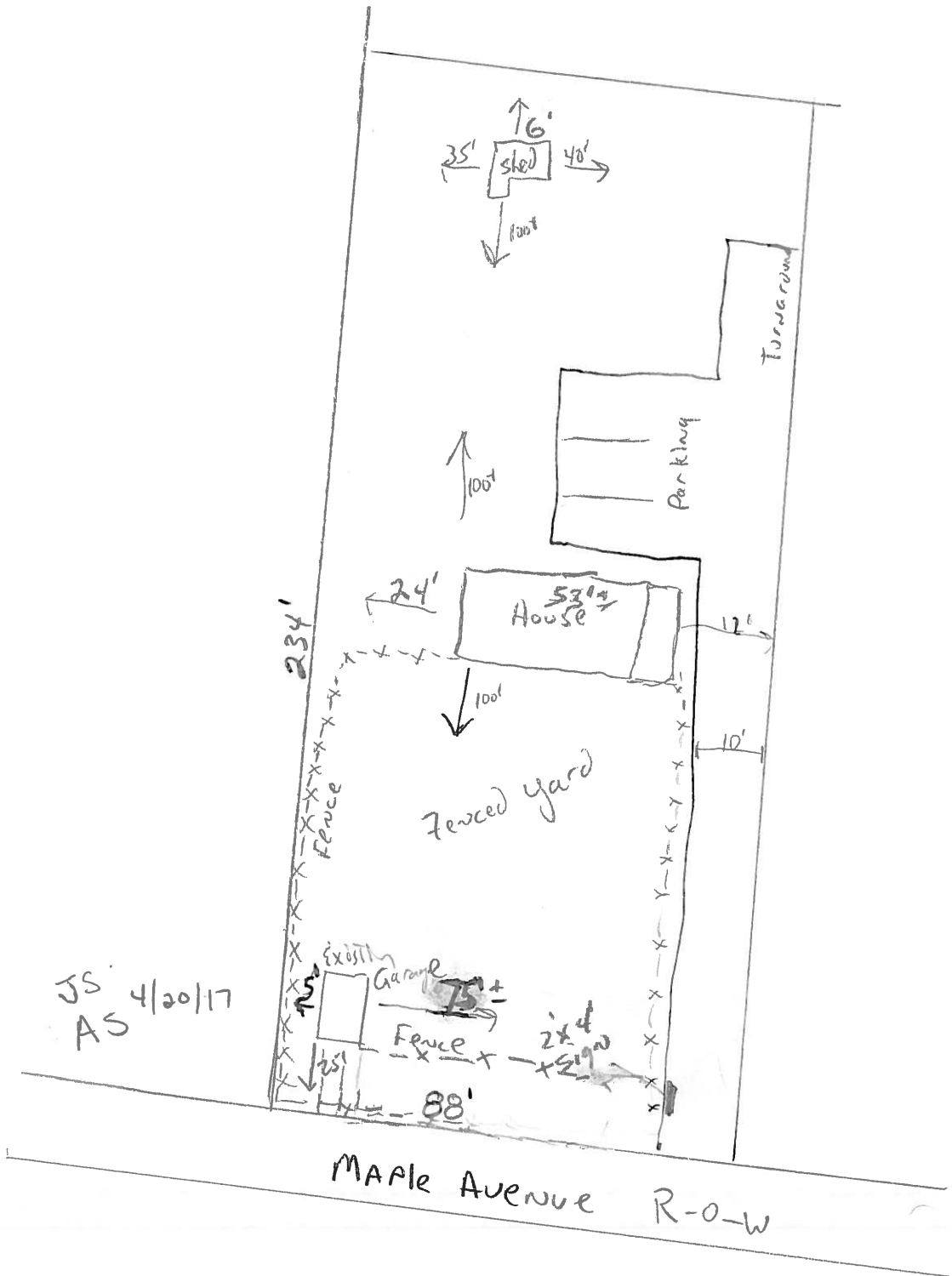

JS 4/20/17
AS

MAPLE Avenue R-O-W

Conditional Use Permit Application
Alisha's Child Care
James, Jr. and Alisha Shimp
130 Maple Avenue (Bakerton)
Harpers Ferry, WV 25425
April 19, 2017

Adjoining Property Owners:

Tax Year: 2017

Parcel: 04 3A001100000000

Deeded Owner: LLOYD LEWIS O

Parcel ID: 04 3A001100000000

Tax Year: 2017

Deeded Owner: LLOYD LEWIS O

C/O:

Owner Address: 114 MAPLE AVE

City: HARPERS FERRY

State: WV

Zip: 25425

Tax Year: 2017

Parcel: 04 3A001300000000

Deeded Owner: HOLMES BRUCE E

Parcel ID: 04 3A001300000000

Tax Year: 2017

Deeded Owner: HOLMES BRUCE E

C/O:

Owner Address: PO BOX 8

City: BAKERTON

State: WV

Zip: 25410

Tax Year: 2017

Parcel: 04 3A001700000000

Deeded Owner: MAIER JOSEPH D & SEYANG

Parcel ID: 04 3A001700000000

Tax Year: 2017

Deeded Owner: MAIER JOSEPH D & SEYANG

C/O:

Owner Address: PO BOX 176

City: BAKERTON

State: WV

Zip: 25410

Tax Year: 2017

Parcel: 04 3A002100000000

Deeded Owner: FUNKHOUSER DAVID C & CYNTHIA D

Parcel ID: 04 3A002100000000

Tax Year: 2017

Deeded Owner: FUNKHOUSER DAVID C & CYNTHIA D

C/O:

Owner Address: 215 MAPLE AVE

City: BAKERTON

State: WV

Zip: 25425



BR 4/20/17

#CUP17-03



MAPLE AVE

CHOW CHOW LN

MEADOW DR

P&P

#CUP17-03

2015 Zoning Map Jefferson County, WV



Legend

- Tax District Boundary
- Growth Management Boundary
- Urban Growth Boundary
- Parcels
- Public/Quasi-Public Land
- Appalachian Trail
- Zoning District**
- Major Industrial
- Light Industrial
- Industrial/Commercial
- Office/Commercial Mixed Use
- General Commercial
- Highway Commercial
- Neighborhood Commercial
- Residential/Light Industrial/Commercial
- Residential Growth
- Planned Neighborhood Development
- Rural
- Village
- Incorporated Town

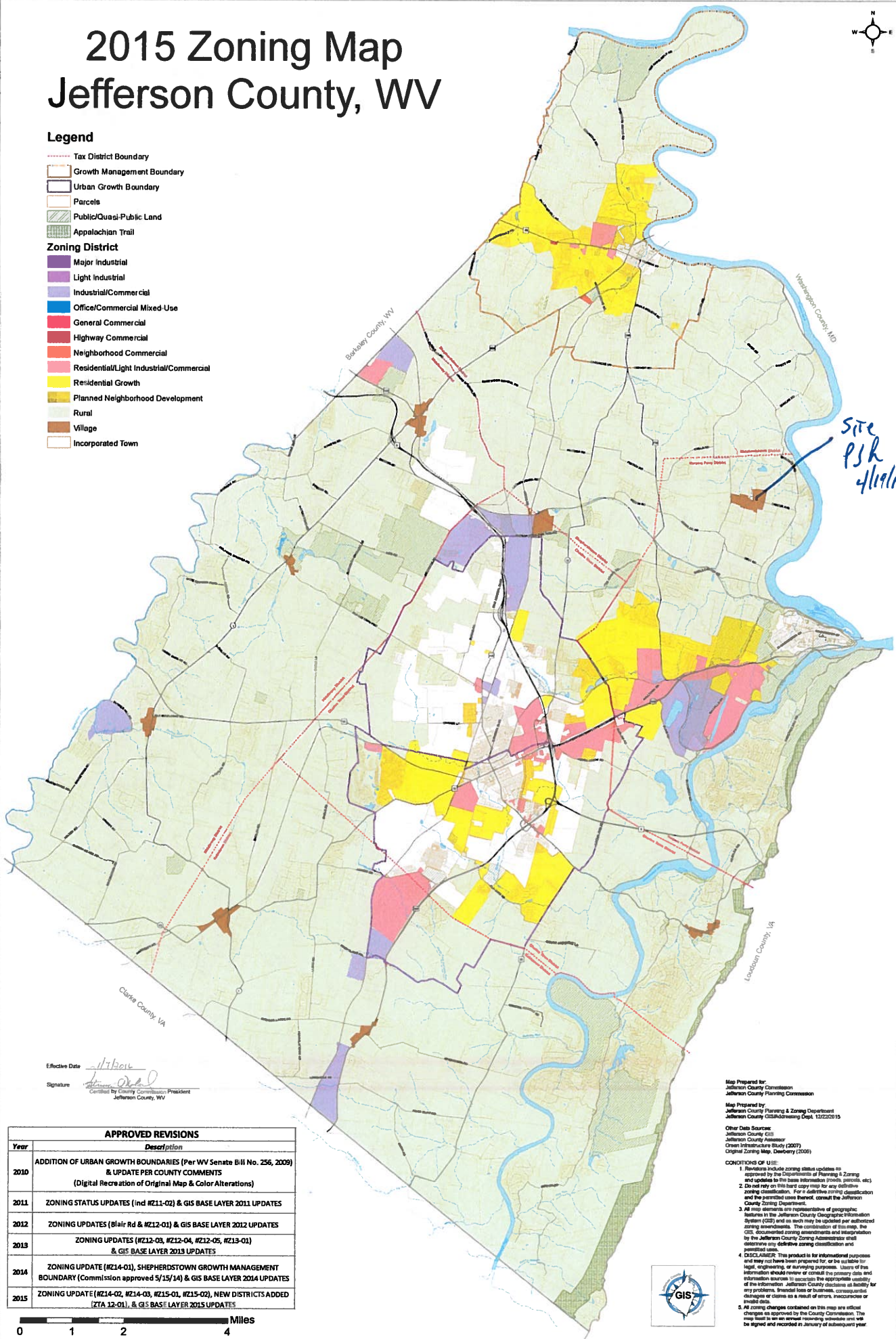

Site
PSK
4/14/17

Effective Date: 4/17/15
 Signature: *[Signature]*
 Certified by County Commission President
 Jefferson County, WV

Map Prepared for:
 Jefferson County Commission
 Jefferson County Planning Commission

Map Prepared by:
 Jefferson County Planning & Zoning Department
 Jefferson County GIS&Planning Dept. 12/22/2015

Other Data Sources:
 Jefferson County GIS
 Jefferson County Assessor
 Open Infrastructure Study (2007)
 Original Zoning Map, February 2006

CONDITIONS OF USE:

1. Revisions include zoning status updates not approved by the Department of Planning & Zoning and updates to the base information (roads, parcels, etc)
2. Do not rely on this hard copy map for any definitive zoning classification. For a definitive zoning classification and the associated zoning district, consult the Jefferson County Zoning Department.
3. All map elements are representative of geographic features in the Jefferson County Geographic Information System (GIS) and as such may be updated per authorized zoning amendments. The combination of this map, the GIS, documented zoning amendments and interpretation by the Jefferson County Zoning Administration shall determine any definitive zoning classification and potential uses.
4. **DISCLAIMER:** This product is for informational purposes and may not have been prepared for, or be suitable for, legal, engineering, or surveying purposes. Users of this information should review or consult the primary data and information sources to ascertain the appropriate usability of the information. Jefferson County disclaims all liability for any problems, incidental loss or business, consequential damages or claims as a result of errors, inaccuracies or omissions.
5. All zoning changes contained on this map are official changes as approved by the County Commission. The map shall be an annual recording schedule and will be signed and recorded in January of subsequent year.



APPROVED REVISIONS	
Year	Description
2010	ADDITION OF URBAN GROWTH BOUNDARIES (Per WV Senate Bill No. 256, 2009) & UPDATE PER COUNTY COMMENTS (Digital Recreation of Original Map & Color Alterations)
2011	ZONING STATUS UPDATES (Ind #Z11-02) & GIS BASE LAYER 2011 UPDATES
2012	ZONING UPDATES (Blair Rd & #Z12-01) & GIS BASE LAYER 2012 UPDATES
2013	ZONING UPDATES (#Z13-03, #Z13-04, #Z13-05, #Z13-01) & GIS BASE LAYER 2013 UPDATES
2014	ZONING UPDATE (#Z14-01), SHEPHERDSTOWN GROWTH MANAGEMENT BOUNDARY (Commission approved 5/15/14) & GIS BASE LAYER 2014 UPDATES
2015	ZONING UPDATE (#Z14-02, #Z14-03, #Z15-01, #Z15-02), NEW DISTRICTS ADDED (ZTA 12-01), & GIS BASE LAYER 2015 UPDATES

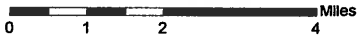





#CUP17-03

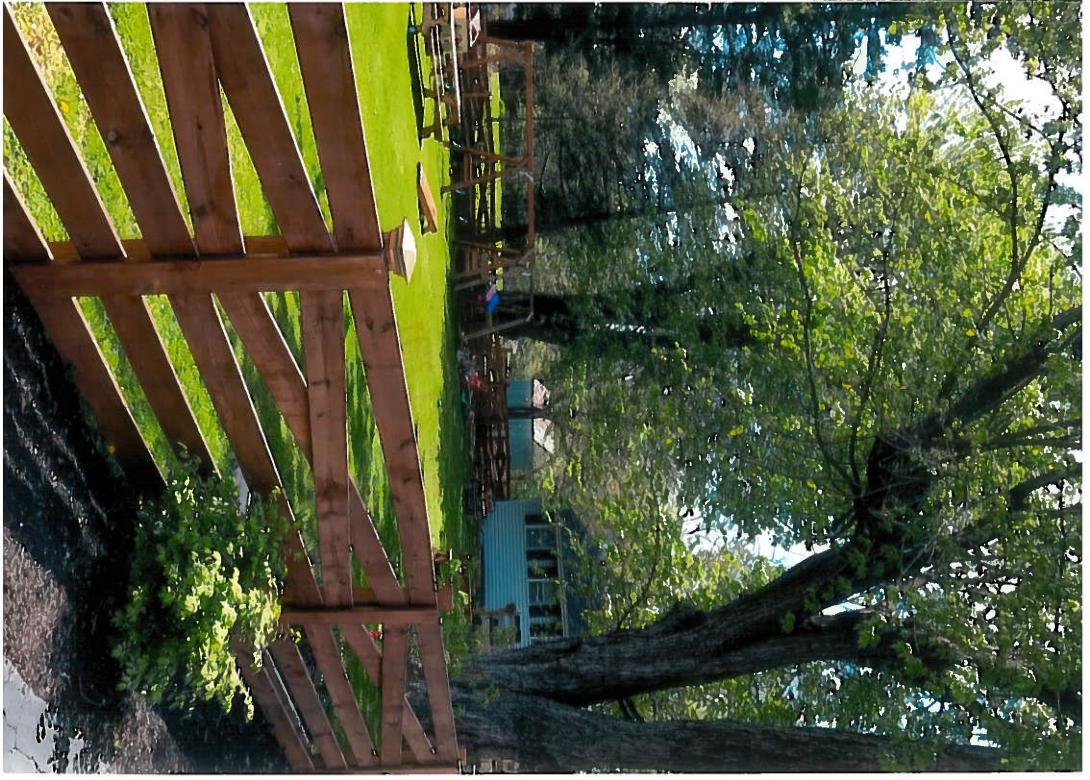

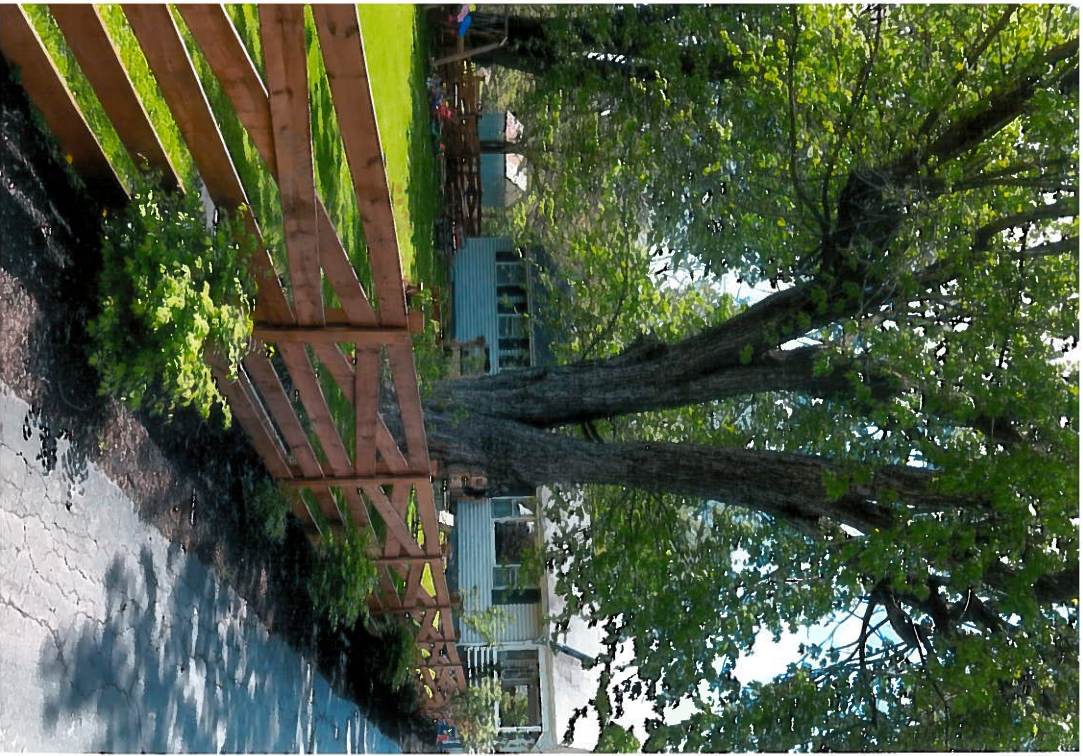

Staff Report
 Jefferson County Board of Zoning Appeals Meeting
 May 25, 2017

**Timothy Johnson Middleway Antique Shop and Information Center
 Conditional Use Permit Request (#CUP17-02)**

Item #5 Request for a conditional use permit for a proposed antique shop and information center to be located in an existing building. The business would utilize an existing gravel parking lot located in the rear of the property and is proposing an 18 sq. ft. sign.

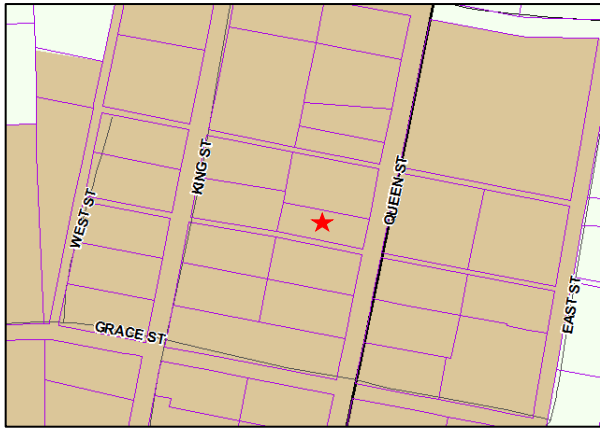
Applicant:	Timothy Johnson
Owner:	Same as owner
Developer:	Same as owner
Consultant:	Paul Raco, P.J. Raco Consulting, LLC
Property Location:	7279 Queen St., Kearneysville
Legal Description & Zoning District:	<p style="text-align: center;">District: Middleway (07); Map: 22A; Parcel: 33; Size: .266 ac; Zone: Village</p> 
Surrounding Properties:	<p style="text-align: center;">Zoning Map Designation: <i>North:</i> Village <i>South:</i> Village <i>East:</i> Village <i>West:</i> Village</p>
History:	Building is located within the Middleway Historic District. Applicant states the building was previously used for commercial purposes.
Waivers/Variiances:	None

STAFF EVALUATION OF REQUEST

SUMMARY OF REQUEST AND PURPOSE OF ORDINANCE REQUIREMENTS

The applicant is requesting a Conditional Use Permit for a proposed antique shop and information center to be located in an existing building. The business would utilize an existing gravel parking lot located in the rear of the property and is proposing an 18 square foot sign.

Section 10.4E requires “All signs accessory to a land use subject to the approval of a Conditional Use Permit shall be proposed within the Conditional Use Permit application and assessed by the Board of Zoning Appeals at the required Public Hearing. Such signs shall be maintained at least 1,000 feet between signs. Consideration of the placement of such signs with less than 1,000 foot intervals shall be determined by the Commercial or Residential Uses adjacent to the subject site. Commercial uses adjacent to the subject site may allow spacing intervals of 300 feet. Any variance from this standard shall require consideration and approval by the Board of Zoning Appeals.”^{2, 17, 21, 23, 32}

Staff Report
Jefferson County Board of Zoning Appeals Meeting
May 25, 2017

**Timothy Johnson Middleway Antique Shop and Information Center
Conditional Use Permit Request (#CUP17-02)**

The applicant is proposing an 18 square foot sign. The applicant will need to address the type of sign, though it is assumed the sign would either be affixed to the front of the building or perhaps a hanging sign attached to the structure.

PROPERTY DESCRIPTION

The lot is approximately a quarter of an acre, situated in the Historic Village of Middleway. The property has two fronts as it is bordered by an alley along the southern boundary line and Queen Street along the eastern boundary. Access to the property is from Queen Street, utilizing a gravel driveway along the northern boundary line, with gravel parking located in the rear.



Staff Report
Jefferson County Board of Zoning Appeals Meeting
May 25, 2017

**Timothy Johnson Middleway Antique Shop and Information Center
Conditional Use Permit Request (#CUP17-02)**



IMPACT ON ADJACENT PROPERTIES

The building has served various purposes over the years, including an office and a barber shop. It has remained vacant for several years. It is anticipated that the proposed use will have a positive impact on adjacent properties since the applicant is working to restore the structure and will continue to maintain the property.

The Middleway Conservancy oversees design standards and renovations; therefore, the character of the building will remain consistent with the historic character of Middleway.

Additional traffic may be generated by the antique shop, but is not anticipated to create an adverse impact on adjacent properties. Based on the applicant's proposal and the support letter from the Middleway Conservancy, the proposed use will be an asset to the community and enhance the overall character of the area.

CONDITIONAL USE PERMIT PROCESS

On March 16, 2017 the County Commission adopted a text amendment which eliminated the LESA/CUP process and replaced with a new CUP Process which requires a public hearing before the Board of Zoning Appeals. Below are the general standards from Section 6.3 of the Zoning Ordinance which the BZA shall consider when reviewing a CUP Application.

“The Board of Zoning Appeals shall have the authority over the issuance or denial of a conditional use permit for uses listed as “Conditional Uses (CU)” in each zoning district. The Board shall have the authority to impose such reasonable conditions and restrictions as are directly related to and incidental to the proposed conditional use permit.”

Staff Report
Jefferson County Board of Zoning Appeals Meeting
May 25, 2017

**Timothy Johnson Middleway Antique Shop and Information Center
Conditional Use Permit Request (#CUP17-02)**

1. The proposed use is compatible with the goals of the adopted Comprehensive Plan.

The applicant has addressed this criteria in their application.

Staff concurs that the Envision Jefferson 2035 Comprehensive Plan supports the adaptive reuse of historic structures and encourages redevelopment and expansion of the County's villages. Middleway is one of the County's eight village areas that are currently identified on the County's zoning map.

2. The proposed use is compatible in intensity and scale with the existing and potential land uses on the adjoining and confronting properties, and poses no threat to public health, safety and welfare.

The applicant has addressed this criteria in their application.

The proposed use of an antique shop and information center appears to be compatible with the surrounding properties. Because Middleway is a Historic District, the appearance of the structure is regulated by the Middleway Conservancy and therefore, should blend with the overall character of the area.

The type of use proposed is not an intense use and is not expected to generate excessive traffic. As no additional square footage is proposed, the use would appear to be compatible in intensity and scale with the surrounding area.

With regard to public health, safety and welfare, it is expected that the renovation and maintenance of a historic structure will help prevent the structure from deteriorating and creating a safety hazard. The establishment of a new business on a main street in a village district would appear to benefit the public's welfare by boosting tourism and providing a resource to local residents.

The only safety concern Staff noted during a site visit was that visibility of Queen Street was limited from the driveway due to the existing two buildings. The design is fairly common for historic towns – structures fronting the main street and off street parking located in the rear.

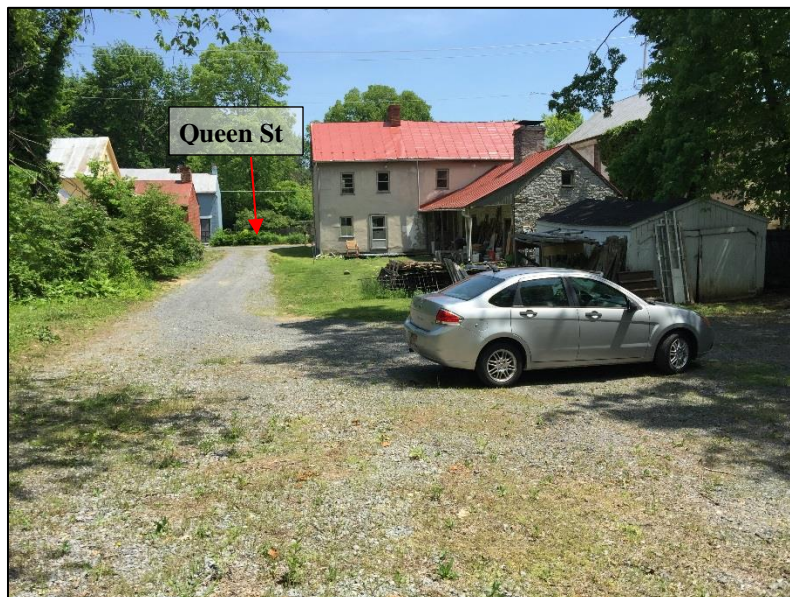

Staff Report
Jefferson County Board of Zoning Appeals Meeting
May 25, 2017

**Timothy Johnson Middleway Antique Shop and Information Center
Conditional Use Permit Request (#CUP17-02)**



While the applicant's sketch does not appear to propose utilizing the alley as a point of ingress or egress, Staff noted that visibility from the alley onto Queen Street was also somewhat impaired due to the wrought iron fence. Again, this was noted due to Queen Street being a frequently travelled road, and though the speed limit is 25 mph, cars appeared to be travelling at higher speeds.

It should be noted that as part of the Village District requirements, Section 5.10E states, "There will be no outdoor storage of equipment, materials, or other stock". This standard should alleviate concern for additional visual obstacles created by merchandise or other materials placed on the porch.



3. The proposed site development shall be such that the use will not hinder nor discourage the appropriate development and use of adjacent land and buildings.

The applicant has addressed this criteria in their application.

The proposed use is complementary to the overall historic character of Middleway, which has the potential to serve as a traditional village, supporting a combination of residential and small business uses. Revitalization of the structure may help initiate additional renovation projects, which could increase property values and preserve a historic town.

Staff Report
Jefferson County Board of Zoning Appeals Meeting
May 25, 2017

**Timothy Johnson Middleway Antique Shop and Information Center
Conditional Use Permit Request (#CUP17-02)**

- 4. Neighborhood character and surrounding property values shall be safeguarded by requiring implementation of the landscaping buffer requirements found in Appendix B and Section 4.11 of this Ordinance.**

While the existing site would likely be unable to accommodate the typical landscaping requirements found in Section 4.11 and Appendix B, the Board has the discretion to apply this standard or a variation of this standard as they deem fit. Section 4.11 allows for opaque fencing in lieu of landscaping.

As noted in the Applicant's request, Staff determined that for existing structures on lots in the Village district, additional distance requirements and buffers as typically required for commercial uses do not apply based on the reduced side and rear setback standard to 6'. Lots in the village district are typically smaller in size and therefore, are unable to accommodate many of the standards for a commercial use. However, it is clear that both the Comprehensive Plan and the Zoning Ordinance support some commercial development within the Village district. For any use listed as a Conditional Use in Appendix C, the Board has the discretion to evaluate the proposed use while considering the character of the area.

- 5. Commercial and Industrial Uses shall be in conformance with Section 8.9 of this Ordinance.**

As part of the Conditional Use Permit application, the applicant was informed of this criteria and shall comply with this standard.



JEFFERSON COUNTY, WEST VIRGINIA
Department of Engineering, Planning and Zoning
Office of Planning and Zoning
 116 East Washington Street, 2nd Floor
 P.O. Box 716
 Charles Town, West Virginia 25414

File #: CUP 17-02
 Mtg. Date: 5/25/17
 Fee Paid: \$ 300.00
 Staff Int.: rlg

Email: zoning@jeffersoncountywv.org

Phone: (304) 728-3228
 Fax: (304) 728-8126

Application for a Conditional Use Permit

Conditional Use Permit process is outlined in Article 6 of the Zoning Ordinance

Project Name

Middleway Antique Shop and Information Center

Property Owner Information

Name: Timothy Johnson
 Business Name: _____
 Mailing Address: 501 Whispering Echoes Drive, Kearneysville, WV 25430 Mail Yes
 Phone Number: 304.725.3072 Email Response: _____ Response: No

Applicant Information

Name: Tim Johnson
 Business Name: _____
 Mailing Address: 7279 Queen Street, Kearneysville, WV 25430 Mail Yes
 Phone Number: 304.725.3072 Email Response: _____ Response: No

Engineer(s), Surveyor(s), or Consultant(s) Information

Name: Paul J Raco
 Business Name: P. J. Raco Consulting, LLC
 Mailing Address: P.O. Box 548, Charles Town, WV 25414 Mail Yes
 Phone Number: 304.676.8256 Email Response: pjraco.consulting@gmail.com Response: No

Physical Property Details

Physical Address: 7279 Queen Street (Middleway)
 Tax District: Middleway Map No: 22A Parcel No. 33
 Parcel Size: 0.2659 67' x 180' Deed Book: 1118 Page No: 570

Zoning District (please check one)

Residential Growth (RG) <input type="checkbox"/>	Industrial Commercial (I-C) <input type="checkbox"/>	Rural* (R) <input type="checkbox"/>	Residential-Light Industrial-Commercial (R-LI-C) <input type="checkbox"/>	Village (V) <input checked="" type="checkbox"/>	Neighborhood Commercial (NC) <input type="checkbox"/>
General Commercial (GC) <input type="checkbox"/>	Highway Commercial (HC) <input type="checkbox"/>	Light Industrial (LI) <input type="checkbox"/>	Major Industrial (MI) <input type="checkbox"/>	Planned Neighborhood Development (PND) <input type="checkbox"/>	Office/Commercial Mixed-Use (OC) <input type="checkbox"/>

* For properties in the Rural Zoning District:
 Is property located on a primary or secondary road? Yes No

Name of Road and/or Route Number: N/A

RECEIVED

APR 19 2017

Sketch Plan (see cover sheet for description)

Attached

A list of all adjacent and confronting property owners (see cover sheet for description)

Attached

Please provide any information or known history regarding this property.

used previously for Antique Sales

Please respond (in detail) to the following statements located in Section 6.3 of the Zoning Ordinance:

1. The proposed use is compatible with the goals of the adopted Comprehensive Plan. *Section 6.3A.1*

SEE Attached

2. The proposed use is compatible in intensity and scale with the existing and potential land uses on the adjoining and confronting properties, and poses no threat to public health, safety, and welfare. *Section 6.3A.2*

See Attached

3. The proposed site development shall be such that the use will not hinder nor discourage the appropriate development and use of adjacent land and buildings. *Section 6.3A.3*

See Attached

4. Neighborhood character and surrounding property values shall be safeguarded by requiring implementation of the landscaping buffer requirements found in Appendix B and Section 4.11 of this Ordinance. *Section 6.3A.4*

I am aware of the landscaping buffer requirements and will adhere to them. N/A per ZA

I am aware of the landscaping buffer requirements; however, I may be seeking a variance to modify them.

5. For properties in the Rural zoning district, roadway adequacy shall be assessed by the Comprehensive Plan's Highway Road Classification Map. If a rural parcel is not shown as commercial on the Future Land Use Guide or does not front on a Principal Arterial, Minor Arterial, or Major Collector road (as identified in the Comprehensive Plan), the applicant shall submit trip generation data, including Average Daily and Peak Hour trips, for the Board of Zoning Appeals to review in conjunction with the Highway Problem Areas Map when determining roadway adequacy for the proposed use. *Section 6.3A.6*

Applicable (Trip Generation Data attached)

Not Applicable

The information given is correct to the best of my knowledge. **Original Signature Required.**

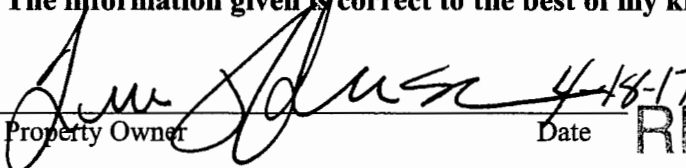
X 

Property Owner

Date

RECEIVED

Property Owner

Date

APR 19 2017

Conditional Use Permit Application
Middleway Antique Shop and Information Center
7279 Queen Street (Middleway)
Kearneysville, WV 25430
April 17, 2017

Brief Narrative on Proposed Project:

The Applicant purchased the John Smith House in the Historic District of Middleway. This structure is one of the oldest structures in West Virginia. The house was purchased from the Middleway Conservancy Association, Inc. with the understanding that it would be used as an Antique Shop and Visitor's and Information Center. A letter from the Conservancy Association is attached. The Historic Landmarks Commission was also consulted and were in attendance at the Pre-Proposal Conference held by the Planning, Zoning and Engineering Staff on January 25, 2017. All of those in attendance agreed that this was an appropriate use that would allow the Owner to restore the house.

When the Village Districts were created in Jefferson County as a part of the Zoning Ordinance, the intent was to allow the adaptive reuse of structures without the need for a site plan since the structures already were existing. The Conditional Use process was established to address the use to make sure that the use was compatible in the Village and would serve the Village.

In this case, the Middleway Village is also a Historic District, so the proposal also needs to seek comments from the appropriate Historic Groups associated with the District. The Middleway Conservancy has deemed the proposed use as an Antique Shop and Information Center to be compatible within the Middleway Village.

Conversion of existing structures in Villages do not need to conform to any buffering or landscaping requirements and most setbacks. The John Smith House meets those setback requirements as determined by the Zoning Administrator.

The proposed plan includes the renovation and restoration of the historic structure that would allow both antique sales and visitor information to be displayed. The total square footage involved will be determined by plans prepared by an Architect and by what will be permitted from Building Code Compliance. However, the total square footage will be contained within the structure. The house is served by an existing driveway and will utilize an existing off-street area for parking in the rear that has enough spaces per the requirements of the zoning ordinance.

The proposal will include a sign with the name of the shop and possibly other descriptive information. The sign will not be bright colors and will not exceed 18 sq. ft.

RECEIVED

APR 19 2017

JEFFERSON COUNTY PLANNING,
ZONING & ENGINEERING

Conditional Use Permit Application
Middleway Antique and Visitor's Center
7279 Queen Street (Middleway)
Kearneysville, WV 25430
April 17, 2017

Conditional Use Criteria:

1. *The proposed use is compatible with the goals of the adopted Comprehensive Plan:*

A proposed Antique Shop in an existing historic house and historic district is compatible with the Comprehensive Plan. Throughout the plan, it endorses the adaptive reuse and renovation/restoration of historic structures. In this case, the Middleway Conservancy has approved the plan to move forward with the restoration and use of the property for both the Information Center and the Antique Shop.

Page 28 of the Comprehensive Plan states:

"In many cases, the repurposing of a building not only benefits the community by redefining the fabric of a neighborhood, but tends to be less costly than new construction once financial incentives are factored into the total cost. The reuse of older buildings also benefits the environment by retaining a building that might otherwise end in a landfill, saving the use of new building materials, and not developing on existing farmland or open space. With abandoned or underutilized structures, the concept of reutilization and revitalization is something that should be explored; however, at times the State Building Code makes rehabilitation of existing structures difficult."

However, the narrative on Page 4 is the statement that most reflects the proposal's conformance and compatibility with the Envision Jefferson 2035 Comprehensive Plan:

"Rehabilitation of Historic Structures

Rehabilitation and re-purposing buildings in historic districts is key to maintaining community identity and an economically sound investment in the community. Many of the village areas in Jefferson County were established around a small center with at least one and traditionally several mixed-use structures. These structures tended to be of a live-work form, with a shopkeeper having their business on the ground floor and living quarters either at the rear of the store or on an upper floor. Other types of uses typically include one or more civic buildings such as a church, post office, or small school.

Over time, maintenance on structures was deferred, and a number of the buildings became underutilized as the population aged, schools were consolidated, and businesses closed. With the focus on increasing the viability of the villages, including the revitalization of the historic downtowns it is important to make it possible for businesses to relocate into these centers and be successful. By working to ensure that funding and other resources are available to assist in the rehabilitation of these

RECEIVED
APR 19 2017

structures, it is hoped that the viability of businesses in the village will be heightened and retention of key structures that enhance the village atmosphere will take place.”

These statements in the Plan recognize that the allowance for adaptive reuse and re-purposing buildings is an incentive for individuals to restore and renovate existing historic structures. Renovation and restoration is a costly process and these costs need to be offset by allowing appropriate uses within the rehabilitated structures. The proposed use as an Antique Shop and Information Center is very compatible with the Comprehensive Plan.

Finally, the very first recommendation under the Village section of the Comprehensive Plan (Page 45) makes it clear that the proposal is consistent with the Plan:

“Village Recommendations (Goal 3)

1. Create village plans for the redevelopment and expansion of the County’s villages through collaboration with key stakeholders.
 - a. Identify opportunities for restoration, rehabilitation and adaptive reuse of structures within village areas.”

This proposed Antique Shop conforms totally to this recommendation in the Comprehensive Plan.

2. The proposed use is compatible in intensity and scale with the existing and potential land uses on the adjoining and confronting properties, and poses no threat to public health, safety, and welfare:

The property is located on the main street of Middleway. The structure is located just off the road as was typical for small villages and towns. It is typical of a main street central business district. The structure is like many of the existing structures in the historic district. At one point, this structure was used for Antique sales, so this use was conforming in the past. The renovation and restoration of this structure for the requested use may stimulate others along Queen Street to do the same. As illustrated in the Plan, the intent of Village Districts is to allow the utilization of existing structures for small scale commercial uses to revitalize and serve the community. This proposal has the approval of the Conservancy and should be a good start to revitalize Middleway.

Since the structure exists and already has off-street parking, it should not impact the neighboring structures. One side is adjacent to a platted Right of Way. The Applicant will utilize the existing entrance, parking and septic system, so there will be no impact on the health, safety and welfare of the community. As stated earlier, the structure was previously used for Antique sales. The Applicant is also proposing a waiver from any site plan requirement to minimize any construction efforts on the property not associated with the actual renovation of the building.

Furthermore, this proposal will not impact the intensity of any potential land uses on the neighboring property in any way. As a matter of fact, it will positively impact the neighborhood and hopefully spur other restoration efforts in Middleway.

RECEIVED

APR 19 2017

JEFFERSON COUNTY PLANNING,
ZONING & ENGINEERING

3. The proposed site development shall be such that the use will not hinder nor discourage the appropriate development and use of adjacent land and buildings:

As stated earlier, the Applicant strongly believes the contrary. This proposal will have a positive impact on the adjacent land and buildings. In fact, the Applicant believes that this proposal may actually encourage appropriate development on the adjacent properties. There will be no construction on the property since the parking area and driveway already exists.

Also, the restoration of the building should enhance the property values in the area. The renovated structure will be much more aesthetically pleasing. This adaptive reuse will allow the rehabilitation of a very historic structure.

4. Landscaping Buffer:

This is not applicable in an existing structure that is located in the Village District.

5. Rural District Roadway Adequacy:

This is not applicable since this property is not in the Rural District.

RECEIVED

APR 19 2017

JEFFERSON COUNTY PLANNING,
ZONING & ENGINEERING

GRACE ST

QUEEN ST

Queen Street Midway

Converted to Antique & Information Center

House to be

BR BR
4/15/17

Generally
N
↓

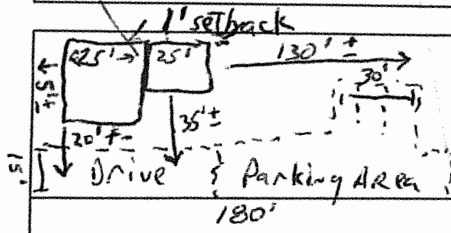

67'

RECEIVED

APR 19 2017

JEFFERSON COUNTY PLANNING
ZONING & ENGINEERING

Middleway Conservancy Association, Inc.

175 East Street
Middleway, WV 25430

13 January 2017

To whom it may concern:

The Middleway Conservancy Association has no objection to the proposal of Tim Johnson in establishing an antique shop on his property at 7279 Queen Street, Kearneysville (Middleway), WV 25430. Mr. Johnson has agreed that the store will include sufficient space to display pictures, maps, brochures, publications, artifacts and other such information regarding Middleway history and architecture.

We believe this use of the building is an appropriate use of the property and will enhance the attractiveness of the village.

Sincerely,

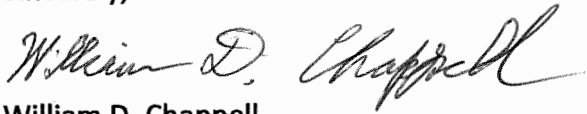

William D. Chappell

Vice-Chairman

Middleway Conservancy Association

304-724-2242

RECEIVED

APR 19 2017

JEFFERSON COUNTY PLANNING,
ZONING & ENGINEERING

Conditional Use Permit Application
Middleway Antique Shop and Information Center
7279 Queen Street (Middleway)
Kearneysville, WV 25430
April 17, 2017

Adjoining Property Information:

Tax Year: 2017

Parcel: 07 22A003400000000

Deeded Owner: RING LAWRENCE W JR

Parcel ID: 07 22A003400000000

Tax Year: 2017

Deeded Owner: RING LAWRENCE W JR

C/O:

Owner Address: 7313 QUEEN ST

City: KEARNEYSVILLE

State: WV

Zip: 25430

Tax Year: 2017

Parcel: 07 22A002600000000

Deeded Owner: BERRY LLOYD A III

Parcel ID: 07 22A002600000000

Tax Year: 2017

Deeded Owner: BERRY LLOYD A III

C/O:

Owner Address: HC 65 BOX 280

City: HARMAN

State: WV

Zip: 26270

RECEIVED

APR 19 2017

JEFFERSON COUNTY PLANNING,
ZONING & ENGINEERING

Tax Year: 2017

Parcel: 07 22A002700000000

Deeded Owner: BARROW MARION L

Parcel ID: 07 22A002700000000

Tax Year: 2017

Deeded Owner: BARROW MARION L

C/O:

Owner Address: 1223 DOUBLE CHURCH RD

City: STEPHENS CITY

State: VA

Zip: 22655

Tax Year: 2017

Parcel: 07 22A003200000000

Deeded Owner: GUPTA SABHASH C

Parcel ID: 07 22A003200000000

Tax Year: 2017

Deeded Owner: GUPTA SABHASH C

C/O:

Owner Address: PO BOX 352

City: GAMBRILLS

State: MD

Zip: 21054

RECEIVED

APR 19 2017

JEFFERSON COUNTY PLANNING,
ZONING & ENGINEERING

Tax Year: 2017

Parcel: 07 22A006200000000

Deeded Owner: TOBORG MARY A-TR

Parcel ID: 07 22A006200000000

Tax Year: 2017

Deeded Owner: TOBORG MARY A-TR

C/O:

Owner Address: 3201 CREST AVE

City: CHEVERLY

State: MD

Zip: 20785

Tax Year: 2017

Parcel: 07 22A006400000000

Deeded Owner: SMITH TIMOTHY D ET AL

Parcel ID: 07 22A006400000000

Tax Year: 2017

Deeded Owner: SMITH TIMOTHY D ET AL

C/O:

Owner Address: 132 NO NAME LN

City: KEARNEYSVILLE

State: WV

Zip: 25430

RECEIVED

APR 19 2017

JEFFERSON COUNTY PLANNING,
ZONING & ENGINEERING

2015 Zoning Map Jefferson County, WV



Legend

- Tax District Boundary
- Growth Management Boundary
- Urban Growth Boundary
- Parcels
- Public/Quasi-Public Land
- Appalachian Trail
- Zoning District**
- Major Industrial
- Light Industrial
- Industrial/Commercial
- Office/Commercial Mixed-Use
- General Commercial
- Highway Commercial
- Neighborhood Commercial
- Residential/Light Industrial/Commercial
- Residential Growth
- Planned Neighborhood Development
- Rural
- Village
- Incorporated Town

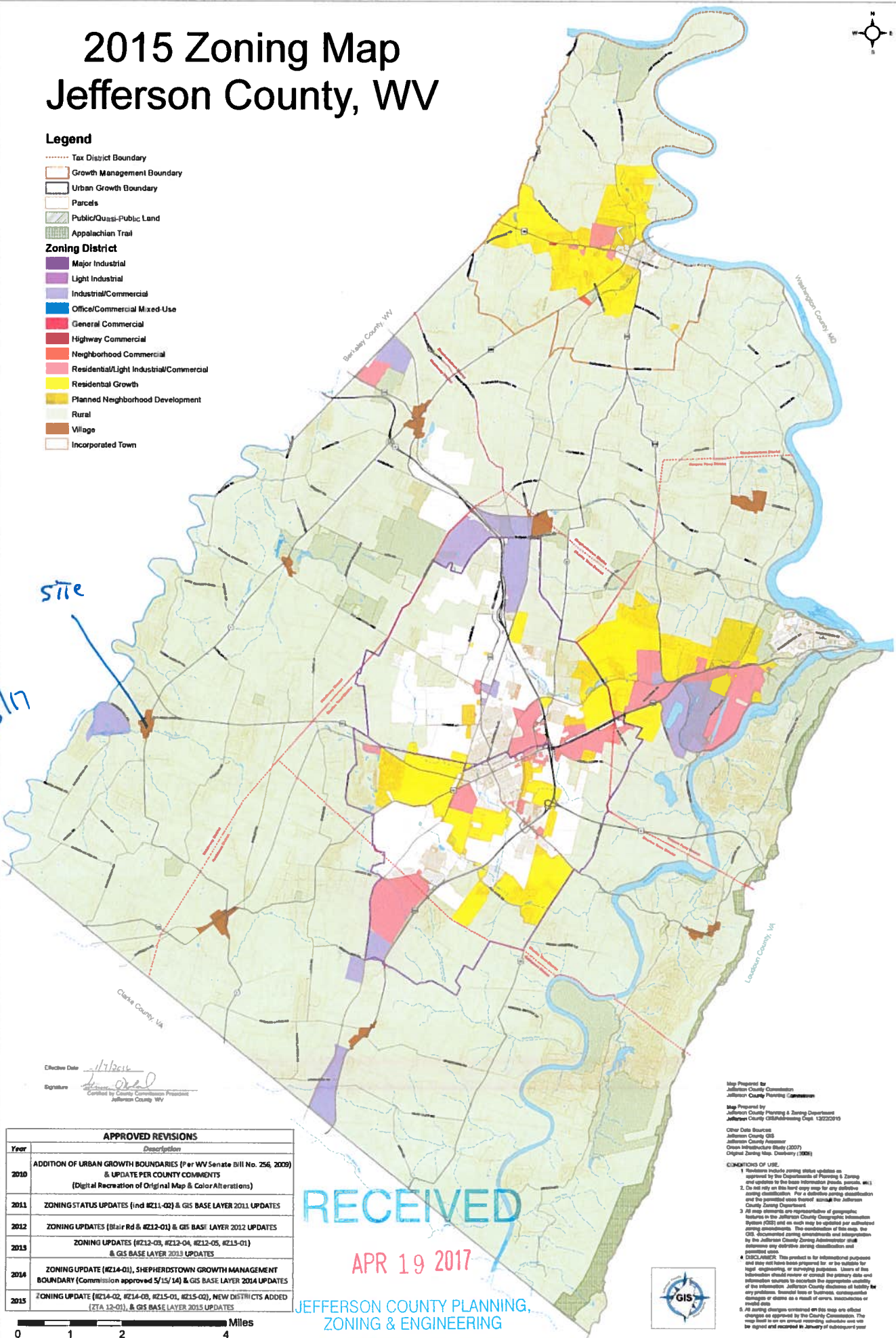

*PK
4/18/17*

site

Effective Date: *4/17/2016*
 Signature: *[Signature]*
 County Planning & Zoning Department
 Jefferson County, WV

Map Prepared for:
 Jefferson County Commission
 Jefferson County Planning Commission

Map Prepared by:
 Jefferson County Planning & Zoning Department
 Jefferson County GIS/Planning Dept. 12222015

Other Data Sources:
 Jefferson County GIS
 Jefferson County Assessor
 Open Infrastructure Study (2007)
 Original Zoning Map, December (2008)

APPROVED REVISIONS	
Year	Description
2010	ADDITION OF URBAN GROWTH BOUNDARIES (Per WV Senate Bill No. 256, 2009) & UPDATE PER COUNTY COMMENTS (Digital Recreation of Original Map & Color Alterations)
2011	ZONING STATUS UPDATES (incl #Z11-02) & GIS BASE LAYER 2011 UPDATES
2012	ZONING UPDATES (Blair Rd & #Z12-01) & GIS BASE LAYER 2012 UPDATES
2013	ZONING UPDATES (#Z12-03, #Z12-04, #Z12-05, #Z13-01) & GIS BASE LAYER 2013 UPDATES
2014	ZONING UPDATE (#Z14-01), SHEPHERDSTOWN GROWTH MANAGEMENT BOUNDARY (Commission approved 5/15/14) & GIS BASE LAYER 2014 UPDATES
2015	ZONING UPDATE (#Z14-02, #Z14-03, #Z15-01, #Z15-02), NEW DISTRICTS ADDED (ZTA 12-01), & GIS BASE LAYER 2015 UPDATES

RECEIVED
 APR 19 2017

JEFFERSON COUNTY PLANNING,
 ZONING & ENGINEERING

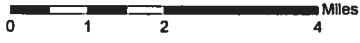

- CONDITIONS OF USE:**
1. Jefferson's zoning status updates are prepared by the Departments of Planning & Zoning and updated by the latest information from parcel #s. 1. Do not rely on this hard copy map for any definitive zoning information. For a definitive zoning classification and the permitted uses thereof consult the Jefferson County Zoning Department.
 2. All map elements are representative of geographic features in the Jefferson County Geographic Information System (GIS) and as such may be updated per authorized zoning amendments. The combination of this map, the GIS, documented zoning amendments and interpretations by the Jefferson County Zoning Administrator shall determine any definitive zoning classification and permitted uses.
 3. DISCLAIMER: This product is for informational purposes and may not have been prepared for or be suitable for legal engineering or surveying purposes. Users of this information should review or consult the appropriate county and information resources to ascertain the appropriate accuracy of the information. Jefferson County disclaims all liability for any problems, financial loss or business, consequential damages or claims as a result of errors, inaccuracies or omissions.
 4. All zoning changes contained on this map are official changes as approved by the County Commission. This map shall be an annual recording schedule and will be signed and recorded in January of subsequent year.



RECEIVED

APR 19 2017

JEFFERSON COUNTY PLANNING,
ZONING & ENGINEERING



PR
4/15/17

GRACE ST

QUEEN ST

EXISTING
Parking
TRUCK
EX DRIVE

KING ST

RECEIVED

APR 13 2017

JEFFERSON COUNTY PLANNING
ZONING & ENGINEERING

Staff Report
 Jefferson County Board of Zoning Appeals Meeting
 May 25, 2017

Johnson Variance Request (#ZV17-07)

Item #6 Variance request from Section 4.10A to waive the requirement of a site plan due to the need for a paved parking lot. Applicant is requesting to utilize existing gravel parking lot as part of Conditional Use Permit application (CUP17-02).

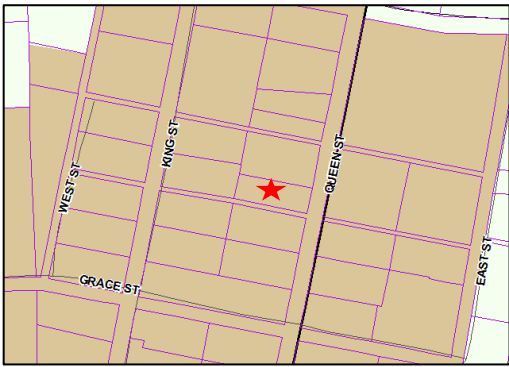
Applicant:	Timothy Johnson
Owner:	Same as above
Developer:	N/A
Consultant:	Paul J. Raco, P.J. Raco Consulting, LLC
Property Location:	7279 Queen Street, Kearneysville, WV 25430
Legal Description & Zoning District:	District: Middleway (07); Map: 22A; Parcel: 33 Size: .27 acre; Zone: Village 
Surrounding Properties:	Zoning Map Designation: <i>North: Village South: Village</i> <i>East: Village West: Village</i>
History:	The subject parcel is referred to as the John Smith House.
Waivers/Variances:	None
Approved Activity:	Residential

STAFF EVALUATION OF REQUEST

Summary of Request and Purpose of Ordinance Requirements

The applicant is requesting a variance from Section 4.10A to allow a change in use to occur without processing a Site Plan. The change in use requires approximately three paved parking spaces, which would necessitate a Site Plan. The submission of a Site Plan would then require buffering and landscaping, which may not be feasible given the location of the existing building and parking. The applicant is requesting to waive the requirement for a site plan which would allow them to utilize the existing gravel parking area.

The purpose of a site plan requirement is to ensure that a site is developed in a manner that protects the public health, safety, and welfare, and also helps to protect the character of a community. The Zoning Ordinance and Subdivision Regulations require that the following elements are reflected in a site plan:

- Stormwater Management
- Buffering of adjacent properties via landscaping and/or fencing
- Adequate parking
- Setbacks from property lines and roads

Staff Report
Jefferson County Board of Zoning Appeals Meeting
May 25, 2017

Johnson Variance Request (#ZV17-07)



Existing structures in the Village zoning district are permitted to utilize a reduced setback standard of 6' and are not subject to additional buffer or distance requirements. In a previous version of the Zoning Ordinance, applicants were permitted to request modifications to parking requirements as part of a Conditional Use Permit application. It appears that the May 1, 2014 set of text amendments, which included the addition of new zoning districts, may have inadvertently eliminated the provision which allowed applicants to request a deviation from parking standards as part of the CUP process. Staff is presenting a draft text amendment to Section 5.10 before the Planning Commission on May 23 to return to the previous standard, which included a provision that exempted existing buildings in the Village zoning district from processing a Site Plan. The proposed amendment suggests allow existing structures to utilize existing parking, unless additional parking is required. Should additional parking be required, reduced site plan standards are proposed to accommodate typically small lot sizes as found in the Village zoning district. Additionally, as part of said text amendment, Staff is recommending that an Antique Shop be a principal permitted use in the Village zoning district, as it is an appropriate use based on the goals of the Envision Jefferson 2035 Comprehensive Plan.

Unique characteristics of property

The lot is approximately a quarter of an acre, situated in the Historic Village of Middleway. The property has two fronts as it is bordered by an alley along the southern boundary line and Queen Street along the eastern boundary line. Access is from Queen Street utilizing a gravel driveway along the northern boundary line, with parking located in the rear.

Impact on adjacent properties

The building has served various purposes over the years, including an office and a barber shop. It has remained vacant for several years. It is anticipated that the proposed use will have a positive impact on adjacent properties since the applicant is working to restore the structure and will continue to maintain the property.

The Middleway Conservancy oversees design standards and renovations; therefore, the character of the building will remain consistent with the historic character of Middleway.

Additional traffic may be generated by the antique shop, but is not anticipated to create an adverse impact on adjacent properties. Based on the applicant's proposal, and the support letter from the Middleway Conservancy, the proposed use will be an asset to the community and enhance the overall character of the area.

Staff Report
Jefferson County Board of Zoning Appeals Meeting
May 25, 2017

Johnson Variance Request (#ZV17-07)

Feasibility of complying with the ordinance by other means

While it is feasible to comply with the Zoning Ordinance and install three paved parking spaces, it seems impractical to require a Site Plan to create permanent off-street parking, which would change the character of the community, because as part of the Site Plan landscaping and buffer standards would also be required, which the site likely cannot accommodate and would necessitate a series of variances.

Staff advised a variance from the Site Plan standard to simplify the process and comply with the intent of the Ordinance which is to exempt existing structures in the Village zoning district from processing a Site Plan.

Should the Board grant the variance to waive the requirement to process a site plan, the applicant will still be subject to Building Code requirements and may be required to provide handicap parking and access to the building. While there are some exemptions from Building Code for historic structures, the Board does not have the authority to waive Building Code requirements.

Conditions of Approval

Should the Board choose to approve this request, possible conditions of approval include:

1. The variance from the required site plan for the provision of permanent off street parking shall be limited to the proposed Antique Shop (CUP17-02) and Information Center.

SECTION OF ORDINANCE TO BE CONSIDERED:

Section 4.10 Site Plan Standards

- A. Submittal and approval of a site plan is required for all commercial, townhouse and multi-family residential, industrial, and institutional development in any district and for all major additions or expansions of existing uses as defined in Article 2, in accordance with the requirements of the Subdivision and Land Development Regulations and this Ordinance.^{23, 26}



JEFFERSON COUNTY, WEST VIRGINIA
Department of Engineering, Planning, and Zoning
Office of Planning and Zoning
 116 East Washington Street, P.O. Box 338
 Charles Town, WV 25414
 www.jeffersoncountywv.org

File Number: ZV17-07
 Staff Initials: rlg
 Meeting Date: 5-28-17
 Fees Paid (\$100 or \$150): 100.00

Email: zoning@jeffersoncountywv.org

Phone: (304) 728-3228

Zoning Variance Request

Variances from the Zoning and Land Development Ordinance must comply with Article 8A-7-11 of the WV State Code. A variance is a deviation from the minimum standards of the ordinance and shall not involve permitting land uses that are otherwise prohibited in the zoning district, nor shall it involve changing the zoning classification of a parcel of land.

Property Owner Information

Name: Timothy Johnson
 Mailing Address: 501 Whispering Echos Drive, Kearneysville, WV 25430
 Phone Number: 304/725-3072 Email: _____

Applicant Contact Information

Name: Tim Johnson Paul J Raco
 Mailing Address: Above and Below
 Phone Number: _____ Email: _____

Applicant Registered Engineer(s), Surveyor(s), or Consultant(s)

Name: Paul J Raco, P. J. Raco Consulting, LLC
 Mailing Address: P.O. Box 548, Charles Town, WV 25414
 Phone Number: 04/676-8256 Email: pjraco.consulting@gmail.com

Physical Property Details

Physical Address: 7279 Queen Street (Middleway)
 City: Kearneysville State: WV Zip Code: 25430
 Tax District: Middleway Map No: 22A Parcel No: 33
 Parcel Size: 67' x 180' 0.2659 Deed Book: 1118 Page No: 570

Zoning District (please check one)

Residential Growth (RG) <input type="checkbox"/>	Industrial Commercial (IC) <input type="checkbox"/>	Rural (R) <input type="checkbox"/>	Residential- Light Industrial- Commercial (R-LI-C) <input type="checkbox"/>	Village (V) <input checked="" type="checkbox"/>	Neighborhood Commercial (NC) <input type="checkbox"/>	General Commercial (GC) <input type="checkbox"/>	
<p align="center">RECEIVED</p> <p align="center">APR 19 2017</p> <p align="center">JEFFERSON COUNTY PLANNING, ZONING & ENGINEERING</p> <p align="center"><small>Place Received Date Stamp Here</small></p>			Highway Commercial (HC) <input type="checkbox"/>	Light Industrial (LI) <input type="checkbox"/>	Major Industrial (MI) <input type="checkbox"/>	Planned Neighborhood Development (PND) <input type="checkbox"/>	Office/Commercial Mixed-Use (OC) <input type="checkbox"/>

On a separate sheet of paper, provide a sketch showing the shape and location of the lot indicating all roads, rights of way, and easements. Show the location of the intended construction or land use indicating building setbacks (i.e. the distance of the structure from all property lines), size, and height. Identify all existing buildings, structures, or land uses on the property. The sketch should show the full extent of the property. Sign and date the sketch.

Is there a Code Enforcement action pending in relation to this property? Yes No

Reference the section of the Zoning Ordinance pertaining to this request: Article 4, Section 4.10

Briefly describe the nature of the variance request:

Waiver of Site Plan (For Paving Gravel Parking Lot)

If this request is for a setback variance, please check one of the following:

Front Setback Side Setback Rear Setback Reduction From _____ to _____

Please explain why granting the variance will NOT adversely affect the public health, safety or welfare, or the rights of adjacent property owners or residents:

SEE ATTACHED

In what way does this request arise from special conditions or attributes which pertain to the property for which a variance is sought and which were not created by the person seeking the variance?

SEE ATTACHED

How will granting this variance eliminate an unnecessary hardship and permit a reasonable use of the land?

See ATTACHED

How will granting this variance allow the intent of the Zoning Ordinance to be observed and substantial justice to be done?

See ATTACHED

Original signature is required. If additional signatures are necessary, please attach a separate piece of paper.

By signing this application, I give permission for the Office of Planning and Zoning staff to walk onto the subject property, if necessary, in order to take photos for the Board of Zoning Appeals staff reports. The information given is correct to the best of my knowledge.

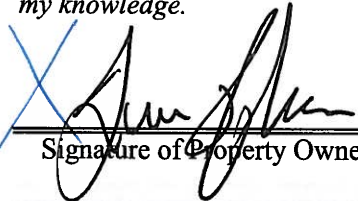
 4-18-17
Signature of Property Owner Date

Signature of Property Owner Date

Notification Requirements (to be completed by staff)

Notice of a public hearing for an appeal shall be advertised in a newspaper having general circulation in the County at least 15 days before the hearing. The subject property shall be posted conspicuously by a zoning notice no less than 28" x 22" in size, at least 15 days before the hearing (pursuant to the Zoning and Land Development Ordinance Section 3.4A(3)(b)).

Date of Public Hearing

Advertising Date

Placard Posting Date

RECEIVED

APR 19 2017

#ZV17-07

Timothy Johnson
Middleway Antique Shop and Information Center
7279 Queen Street in Middleway
Request for a Variance from Article 4, Section 4.10
Jefferson County Zoning Ordinance
April 17, 2017

Brief Description of Request

This request is a variance to allow the existing structure, parking and driveway to be utilized without a need for a site plan. There is a question on whether a site plan is needed when nothing is changing on the site in an existing structure in a Village District. The Staff suggested that a variance from the site plan provisions to allow the parking as it exists would be the conservative way to proceed. Since the Applicant is appearing today for the CUP, the Applicant agreed to process the variance. The purpose of using the parking and driveway as it is (without pavement) is to ensure that there would be no additional impervious area since the property does not currently have a run-off problem. If the parking and driveway were required to be paved, then the possibility may cause an unnecessary problem. The proposal, as recommended by the Conservancy Association, is to keep everything exactly how it is, except for the proposed restoration to the actual dwelling. The proposal is as described in the CUP application and is included in the below narrative.

The Applicant purchased the John Smith House in the Historic District of Middleway. This structure is one of the oldest structures in West Virginia. The house was purchased from the Middleway Conservancy Association, Inc. with the understanding that it would be used as an Antique Shop and Visitor's and Information Center. A letter from the Conservancy Association is attached. The Historic Landmarks Commission was also consulted and attended the Pre-Proposal Conference held by the Planning, Zoning and Engineering Staff on January 25, 2017. All of those in attendance agreed that this was an appropriate use that would allow the Owner to restore the house.

When the Village Districts were created in Jefferson County as a part of the Zoning Ordinance, the intent was to allow the adaptive reuse of structures without the need for a site plan since the structures already were existing. The Conditional Use process was established to address the use to make sure that the use was compatible in the Village and would serve the Village.

In this case, the Middleway Village is also a Historic District, so the proposal also needs to seek comments from the appropriate Historic Groups associated with the District. The Middleway Conservancy has deemed the proposed use as an Antique Shop and Information Center to be compatible within the Middleway Village.

Conversion of existing structures in Villages do not need to conform to any buffering or landscaping requirements and most setbacks. The John Smith House meets those requirements as determined by the Zoning Administrator.

RECEIVED

APR 19 2017

JEFFERSON COUNTY PLANNING,
ZONING & ENGINEERING

The proposed plan includes the renovation and restoration of the historic structure that would allow both antique sales and visitor information to be displayed. The total square footage involved will be determined by plans prepared by an Architect and by what will be permitted from Building Code Compliance. However, the total square footage will be contained within the structure. The house is served by an existing driveway and will utilize an existing off-street area for parking in the rear that has enough spaces per the requirements of the zoning ordinance.

Keeping everything as is on site is the best approach to the renovation and restoration of the existing structure. This structure was reportedly used as an Antique Shop in the past.

RECEIVED

APR 19 2017

JEFFERSON COUNTY PLANNING,
ZONING & ENGINEERING

Timothy Johnson
Middleway Antique Shop and Information Center
7972 Queen Street in Middleway
Request for a Variance from Article 4, Section 4.10
Jefferson County Zoning Ordinance
April 17, 2017

Four Criteria as Required by Article 6, Section 6.2A:

1. Will not adversely affect the public health, safety or welfare, or the rights of adjacent property owners or residents:

The renovation and restoration of the existing structure will have negligible effect on the neighborhood, because everything including the parking area and driveway exists. So, there should not be any additional impact to the surrounding area. Public health and safety will be addressed, because Health Department approval and County Building Code approval will be necessary at the building permit stage. Regarding public welfare, the Middleway Conservancy has no objection to the conversion of the use and believes that it will be helpful to provide informational services for Middleway. As such, the proposal should be a benefit to the Community without causing any impact since there will be no external site construction work. If in fact the variance is denied, it may create additional problems with pavement causing drainage issues. Additionally, the Applicant is trying to allow the property to remain as historically correct as possible and paving the parking lot would not achieve that effect.

In return, the Community benefits from the Applicant renovating and restoring a historic structure that would otherwise become dilapidated. This restoration improves upon the safety and welfare of the property as it is currently.

2. Arises from special conditions or attributes which pertain to the property for which a variance is sought and which were not created by the person seeking the variance:

The special conditions and attributes of this property is that everything exists. The Zoning Ordinance allows the adaptive reuse of the structures within exiting Villages. In order for the Applicant to renovate the structure, the Comprehensive Plan supports making the process easier to complete. The John Smith House is Historic and it sits in a Historic District, it requires care and money to properly renovate the structure. Requiring any parts of a site plan is not what the original ordinance intended for existing structures in a Village. However, this is particularly true in Middleway because of the historic character of the district. The Conservancy is satisfied with the Applicant's plans.

The restoration of a historic structure and using it for antique sales in a historic district seems to be an appropriate use especially when the structure was used for this purpose

in the past. This type of proposal seems to fit perfectly within the special attributes of the property. The Applicant is improving the property, as opposed to creating a problem.

3. Would eliminate an unnecessary hardship and permit a reasonable use of the land:

The site plan variance would eliminate the need for an engineered site plan for a paved parking lot when an existing area for parking is already graveled. Paving an existing graveled parking lot by itself does not even require a site plan under normal circumstances. So, the allowance of a use that was just approved as a Conditional Use without the need to pave the existing lot would seem to be logical. It would allow the continued renovation of the historic property without paving. This would allow for a reasonable use of the land that was just approved for a Conditional Use. The parcel provides an existing gravel parking lot already and the continued use of the gravel drive and parking area would cause less impact to the area than a paved parking lot. This is especially true for a historically correct restoration in an approved Historic District that has already received the Middleway Conservancy's approval.

4. Will allow the intent of the zoning ordinance to be observed and substantial justice done:

The intent of the Zoning Ordinance regarding site plans is to make sure that properties aren't impacted in a negative way because of inadequate parking and poor drainage. In this case, no drainage problems exist and adequate parking is already provided. There should be no adverse impact for this conversion and renovation. Adding paved parking may actually cause a drainage issue.

Furthermore, the Applicant believes that the Zoning Ordinance and Comprehensive Plan allows and encourages the use of existing structures in the Village Districts without a site plan. This has been discussed with the Zoning Administrator and will be further discussed during the upcoming amendment process.

Based on the above and the brief description, the Applicant believes that substantial justice would be to grant the variance to allow the use and to utilize the existing parking area. Since there will be no disturbed area, no other requirements would initiate a site plan for this use in the village. This approval will allow the important restoration of the John Smith House which will benefit the entire community. Accordingly, the Applicant respectfully asks the Board to grant the relief that we are seeking. Thank you.

#ZV17-07

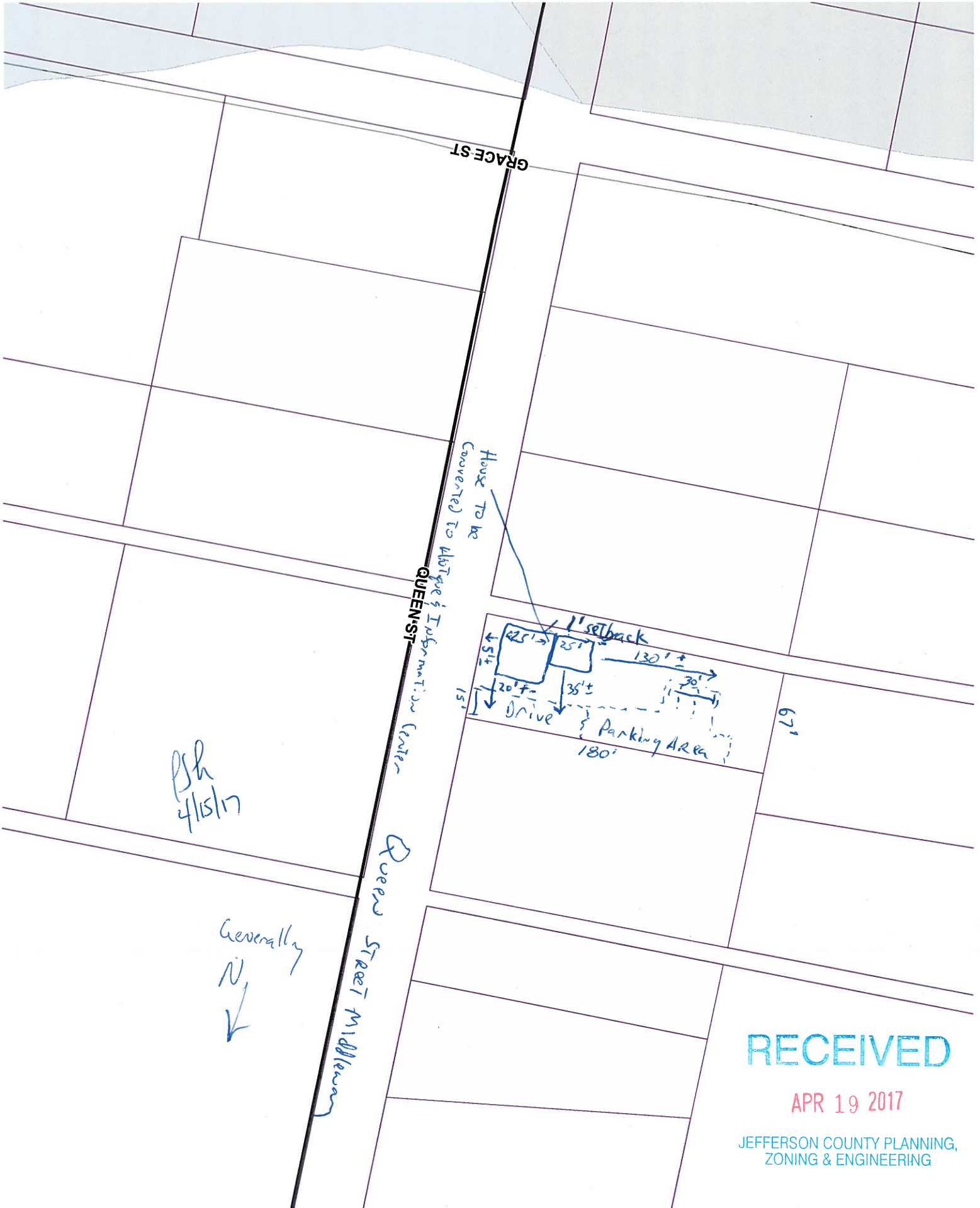

RECEIVED

APR 19 2017

JEFFERSON COUNTY PLANNING,
ZONING & ENGINEERING

PSK 4/15/17

#ZV17-07



GRACE ST

QUEEN ST

Ex Parking

Ex Drive

RECEIVED

SEARCHED
SERIALIZED
INDEXED

PSR 4/15/17

#ZV17-07

GRACE ST

QUEEN ST

Site
APP
22A
P.33
P.33
Dist.

RECEIVED

APR 19 2017

JEFFERSON COUNTY PLANNING,
ZONING & ENGINEERING

2015 Zoning Map Jefferson County, WV



Legend

- Tax District Boundary
- Growth Management Boundary
- Urban Growth Boundary
- Parcels
- Public/Quasi-Public Land
- Appalachian Trail
- Zoning District**
- Major Industrial
- Light Industrial
- Industrial/Commercial
- Office/Commercial Mixed-Use
- General Commercial
- Highway Commercial
- Neighborhood Commercial
- Residential/Light Industrial/Commercial
- Residential Growth
- Planned Neighborhood Development
- Rural
- Village
- Incorporated Town

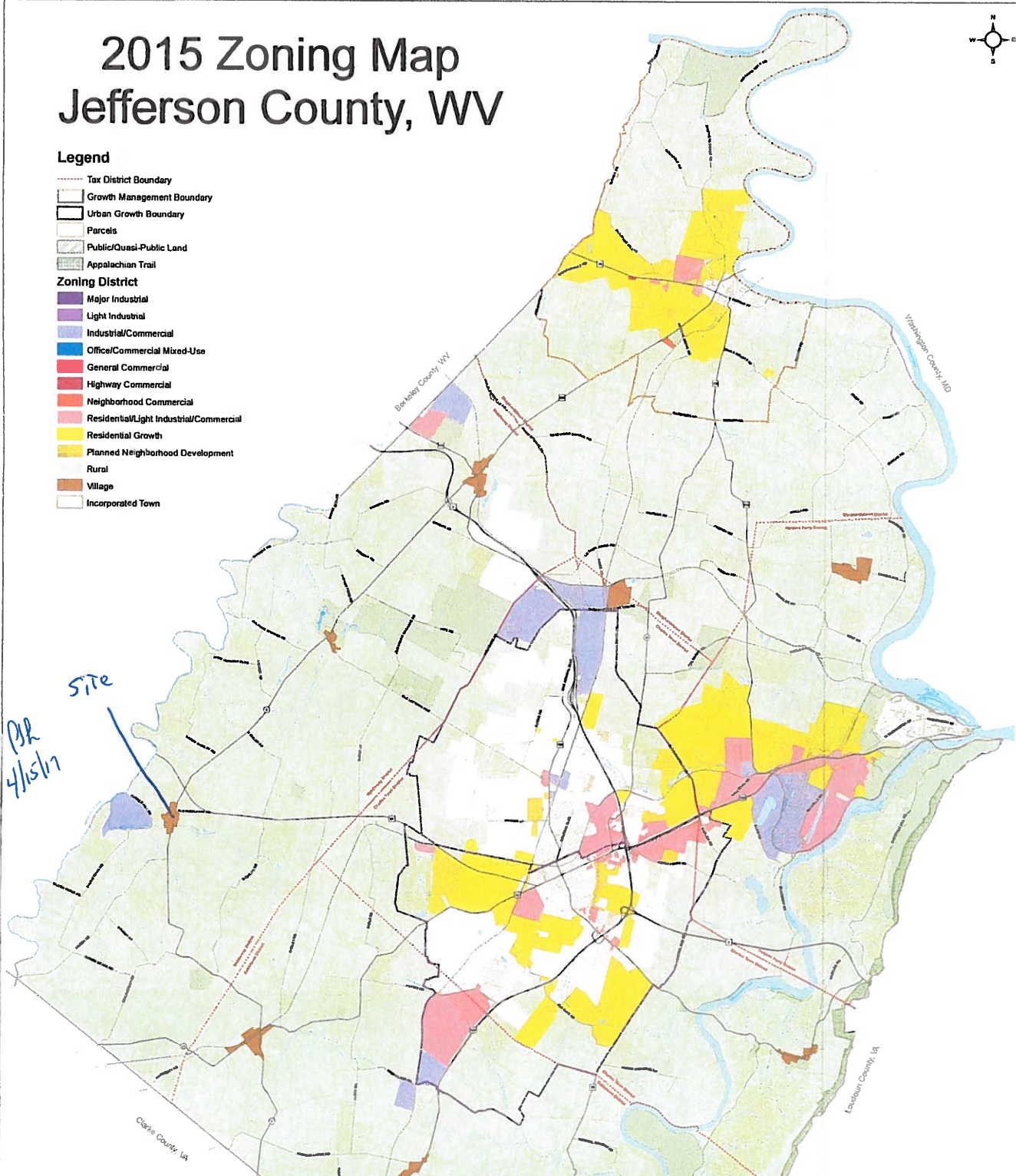

Effective Date: 4/15/16
 Signature: [Signature]
 Certified by County Commission President
 Jefferson County, WV

Map Prepared by:
 Jefferson County Commission
 Jefferson County Planning Commission

Map Prepared by:
 Jefferson County Planning & Zoning Department
 Jefferson County GIS/Addressing Dept. 12/22/2015

Other Data Sources:
 Jefferson County GIS
 Jefferson County Assessor
 Open Infrastructure Survey (2007)
 Original Zoning Map, December (2006)

- CONDITIONS OF USE:**
1. Revisions include zoning status updates as approved by the Departments of Planning & Zoning and updated to the base information (roads, parcels, etc.)
 2. Do not rely on this hard copy map for any definitive zoning classification. For a definitive zoning classification and the parcel/lot/area number, consult the Jefferson County Zoning Department.
 3. All map elements are representative of geographic features in the Jefferson County Geographic Information System (GIS) and do not imply any administrative zoning amendments. This combination of this map, the GIS, documented zoning amendments and interpretation by the Jefferson County Zoning Administrator shall constitute any definitive zoning classification and parcel/lot/area number.
 4. **DISCLAIMER:** This product is for informational purposes and may have been prepared for, or the accuracy for, legal, engineering, or surveying purposes. Users of this information should review or consult the primary data and information sources to ascertain the appropriate usability of the information. Jefferson County declines all liability for any problems, financial loss or business, consequential damages or claims as a result of errors, inaccuracies or omissions.
 5. All zoning changes contained on this map are effective changes approved by the County Commission. The map is to be an annual recurring schedule and will be signed and recorded in January of subsequent year.

APPROVED REVISIONS	
Year	Description
2010	ADDITION OF URBAN GROWTH BOUNDARIES (Per WV Senate Bill No. 256, 2009) & UPDATE PER COUNTY COMMENTS (Digital Recreation of Original Map & Color Alterations)
2011	ZONING STATUS UPDATES (incl #Z11-02) & GIS BASE LAYER 2011 UPDATES
2012	ZONING UPDATES (Blair Rd & #Z12-01) & GIS BASE LAYER 2012 UPDATES
2013	ZONING UPDATES (#Z12-03, #Z12-04, #Z12-05, #Z13-01) & GIS BASE LAYER 2013 UPDATES
2014	ZONING UPDATE (#Z14-01), SHEPHERDSTOWN GROWTH MANAGEMENT BOUNDARY (Commission approved 5/15/14) & GIS BASE LAYER 2014 UPDATES
2015	ZONING UPDATE (#Z14-02, #Z14-03, #Z15-01, #Z15-02), NEW DISTRICTS ADDED (ZTA 12-01), & GIS BASE LAYER 2015 UPDATES

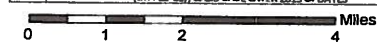

RECEIVED

APR 19 2017

JEFFERSON COUNTY PLANNING
ZONING & ENGINEERING



Staff Report
 Jefferson County Board of Zoning Appeals Meeting
 April 27, 2017

Wright Variance Request (#ZV17-09)

Item #7 Variance from Section 5.7B(1) and Appendix A to reduce the side setback from 15' to 3' for a 20' x 32' accessory structure.

Applicant:	Suzin & Laurence Wright
Owner:	Same as above
Developer:	N/A
Consultant:	N/A
Property Location:	947 Hostler Road, Harpers Ferry
Legal Description & Zoning District:	<p style="text-align: center;">District: Harpers Ferry (04); Map: 15; Parcel 19.1 Size: 1.18 acres; Zone: Rural</p> 
Surrounding Properties:	<p style="text-align: center;">Zoning Map Designation:</p> <p style="text-align: center;"><i>North:</i> Rural <i>South:</i> Rural <i>East:</i> Rural <i>West:</i> Rural</p>
History:	The subject parcel was created as a parent to child transfer and recorded in the Jefferson County Courthouse on March 13, 2007.
Waivers/Variations:	None
Approved Activity:	Residential

STAFF EVALUATION OF REQUEST

a. Summary of Request and Purpose of Ordinance Requirements

The applicant is requesting a variance to reduce the side setback requirement from 15' to 3' to allow for the construction of a 20' x 30' storage structure.

The purpose of side and rear yard setback requirements is to reduce the impact that a land use might have on an adjacent property; to allow adequate space between a structure and a property line so that maintenance of the structure is feasible; to maintain adequate separation between structures for fire prevention purposes; and to allow room for utility easements.

Staff Report
Jefferson County Board of Zoning Appeals Meeting
April 27, 2017

Wright Variance Request (#ZV17-09)

b. Unique characteristics of property

The lot is approximately 1.18 acres. The majority of the lot is densely wooded with a steep slope (contour maps show a 40' slope from the driveway toward the west side property line). As noted on the applicant's sketch, the septic system and drain field is located in the middle of the property. The Health Department requires all structures to maintain a 10' setback from this area.

c. Impact on adjacent properties

A side setback reduction from 15' to 3' would likely have minimal impact on the neighboring property as the proposed dwelling unit for parcel 19 is located approximately 659 feet from the subject parcel. In addition to the distance between the proposed storage structure and the dwelling unit currently under construction on the adjacent property, both parcels are densely wooded which provides a natural buffer between the two properties.

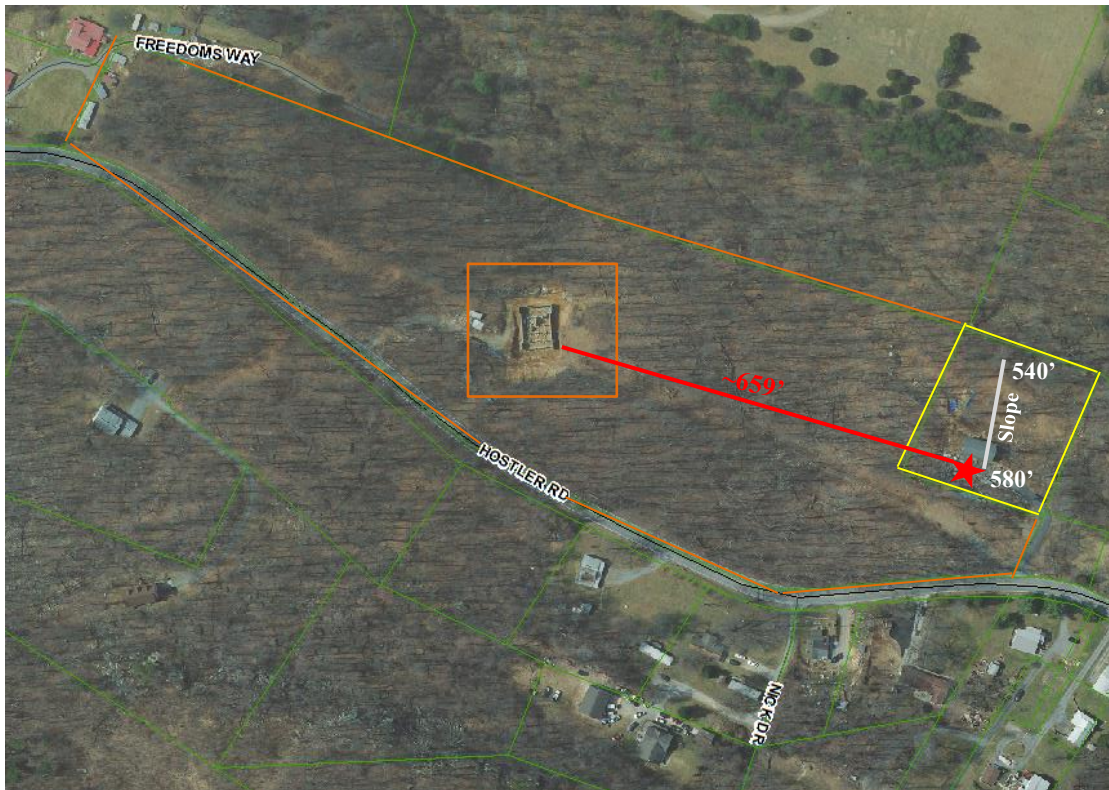

d. Feasibility of complying with the ordinance by other means

Based on the dimensions of the property, the applicant could potentially situate the storage structure in another location to meet setback requirements.

Staff Report
 Jefferson County Board of Zoning Appeals Meeting
 April 27, 2017

Wright Variance Request (#ZV17-09)

e. Conditions of Approval

Should the Board choose to approve this request, possible conditions of approval include:

1. No conditions of approval have been identified.

SECTION OF ORDINANCE TO BE CONSIDERED:

Section 5.7 Rural (R) District^{23, 32}

B. Minimum Lot Area, Lot Width and Yard Requirements²³

1. Setbacks, height, and other site development standards shall be as indicated in Appendix A, Residential Site Development Standards, and Appendix B, Non-Residential Site Development Standards, except as provided elsewhere in this Ordinance.²⁷

Appendix A: Residential Site Development Standards Table^{27, 32}

Rural (R) (See Sec. 5.7)	Dwellings	40,000	N/A	100	45	40	15	*	50	
	Over 2 acres	N/A	N/A	N/A	45	40	15	*	50	
	Single-Family Dwelling with setbacks not previously stipulated by Planning Commission	40,000 sq. ft. to 2 acres	N/A	N/A	N/A	45	25	12	*	12
	30,000 sq. ft. to 39,999 sq. ft.	N/A	N/A	N/A	45	20	10	*	12	
	Under 30,000 sq. ft.	N/A	N/A	N/A	45	20	8	*	12	
Cluster Subdivision	See RG District									



JEFFERSON COUNTY, WEST VIRGINIA
Department of Engineering, Planning, and Zoning
Office of Planning and Zoning
 116 East Washington Street, P.O. Box 338
 Charles Town, WV 25414
 www.jeffersoncountywv.org

File Number: #ZV17-09
 Staff Initials: CPC
 Meeting Date: 05.25.17
 Fees Paid (\$100 or \$150): _____

Email: zoning@jeffersoncountywv.org

Phone: (304) 728-3228

Zoning Variance Request

Variations from the Zoning and Land Development Ordinance must comply with Article 8A-7-11 of the WV State Code. A variance is a deviation from the minimum standards of the ordinance and shall not involve permitting land uses that are otherwise prohibited in the zoning district, nor shall it involve changing the zoning classification of a parcel of land.

Property Owner Information

Name: Suzin and Laurence Wright
 Mailing Address: 947 Hostler Rd, Harpers Ferry, WV 25425
 Phone Number: 304-728-2193 or cell 301-412-2859 Email: smwrighthf1@frontier.com

Applicant Contact Information

Name: (same)
 Mailing Address: _____
 Phone Number: _____ Email: _____

Applicant Registered Engineer(s), Surveyor(s), or Consultant(s)

Name: _____
 Mailing Address: _____
 Phone Number: _____ Email: _____

Physical Property Details

Physical Address: 947 Hostler Rd
 City: Harpers Ferry State: WV Zip Code: 25425
 Tax District: 04 Map No: 15 Parcel No: 19.1
 Parcel Size: 1.18 ac Deed Book: 1034 Page No: 0060

Zoning District (please check one)

Residential Growth (RG)	Industrial Commercial (IC)	Rural (R)	Residential- Light Industrial- Commercial (R-LI-C)	Village (V)	Neighborhood Commercial (NC)	General Commercial (GC)	
<input type="checkbox"/>	<input type="checkbox"/>	<input checked="" type="checkbox"/>	<input type="checkbox"/>	<input type="checkbox"/>	<input type="checkbox"/>	<input type="checkbox"/>	
			Highway Commercial (HC)	Light Industrial (LI)	Major Industrial (MI)	Planned Neighborhood Development (PND)	Office/Commercial Mixed-Use (OC)
			<input type="checkbox"/>	<input type="checkbox"/>	<input type="checkbox"/>	<input type="checkbox"/>	<input type="checkbox"/>

RECEIVED
 APR 28 2017
 JEFFERSON COUNTY PLANNING,
 ZONING & ENGINEERING
Please Receive Date Stamp Here

On a separate sheet of paper, provide a sketch showing the shape and location of the lot indicating all roads, rights of way, and easements. Show the location of the intended construction or land use indicating building setbacks (i.e. the distance of the structure from all property lines), size, and height. Identify all existing buildings, structures, or land uses on the property. The sketch should show the full extent of the property. Sign and date the sketch.

Is there a Code Enforcement action pending in relation to this property? Yes No

Reference the section of the Zoning Ordinance pertaining to this request: 5.7

Briefly describe the nature of the variance request:

We would like to reduce the side setback to three feet in order to build a shed of our desired size. We own the adjacent property and are already using the nearby areas on both sides of the property line for various purposes.

If this request is for a setback variance, please check one of the following:

Front Setback Side Setback Rear Setback Reduction From 15 to 3

Please explain why granting the variance will NOT adversely affect the public health, safety or welfare, or the rights of adjacent property owners or residents:

The uses of the land and impact on the adjacent 11-acre parcel, owned by us, won't be changed in any way. The proposed structure would be no closer to properties owned by others. It doesn't increase the impact on the environment or increase construction safety concerns; it has the less of these factors than most of the alternatives for the shed.

In what way does this request arise from special conditions or attributes which pertain to the property for which a variance is sought and which were not created by the person seeking the variance?

The steep terrain and mature trees limited the placement of the existing elements such as the house, driveway, drain field, etc. The proposed shed would be located in one of the only clear, flat areas. The best alternate location would also require a setback variance in order to fit in the available space and be clear of the septic system.

How will granting this variance eliminate an unnecessary hardship and permit a reasonable use of the land?

Other locations would require extensive excavation on steep slopes, driving heavy machinery across the drain field, construction of driveways, and/or cutting down mature trees that currently enhance the lot. A structure within the allowed area would have to be extremely narrow, and much less useful to us, in order to avoid blocking the driveway.

How will granting this variance allow the intent of the Zoning Ordinance to be observed and substantial justice to be done?

The uses of the land and impact on the other property owners and neighborhood will not be changed or affected in any negative way. The setback reduction would move the shed slightly closer to our other property. A shed of the size we want could enhance the property's appearance by having adequate indoor storage.

Original signature is required. If additional signatures are necessary, please attach a separate piece of paper.

By signing this application, I give permission for the Office of Planning and Zoning staff to walk onto the subject property, if necessary, in order to take photos for the Board of Zoning Appeals staff reports. The information given is correct to the best of my knowledge.

 4/28/17
Signature of Property Owner Date

 4/28/2017
Signature of Property Owner Date

Notification Requirements (to be completed by staff)

Notice of a public hearing for an appeal shall be advertised in a newspaper having general circulation in the County at least 15 days before the hearing. The subject property shall be posted conspicuously by a zoning notice no less than 28" x 22" in size, at least 15 days before the hearing (pursuant to the Zoning and Land Development Ordinance Section 3.4A(3)(b)).

Date of Public Hearing

Advertising Date

Placard Posting Date

RECEIVED
APR 28 2017
JEFFERSON COUNTY PLANNING,
ZONING & ENGINEERING

Wright variance request sketch 2 of 2. Dimensions are approximate

#2117-09

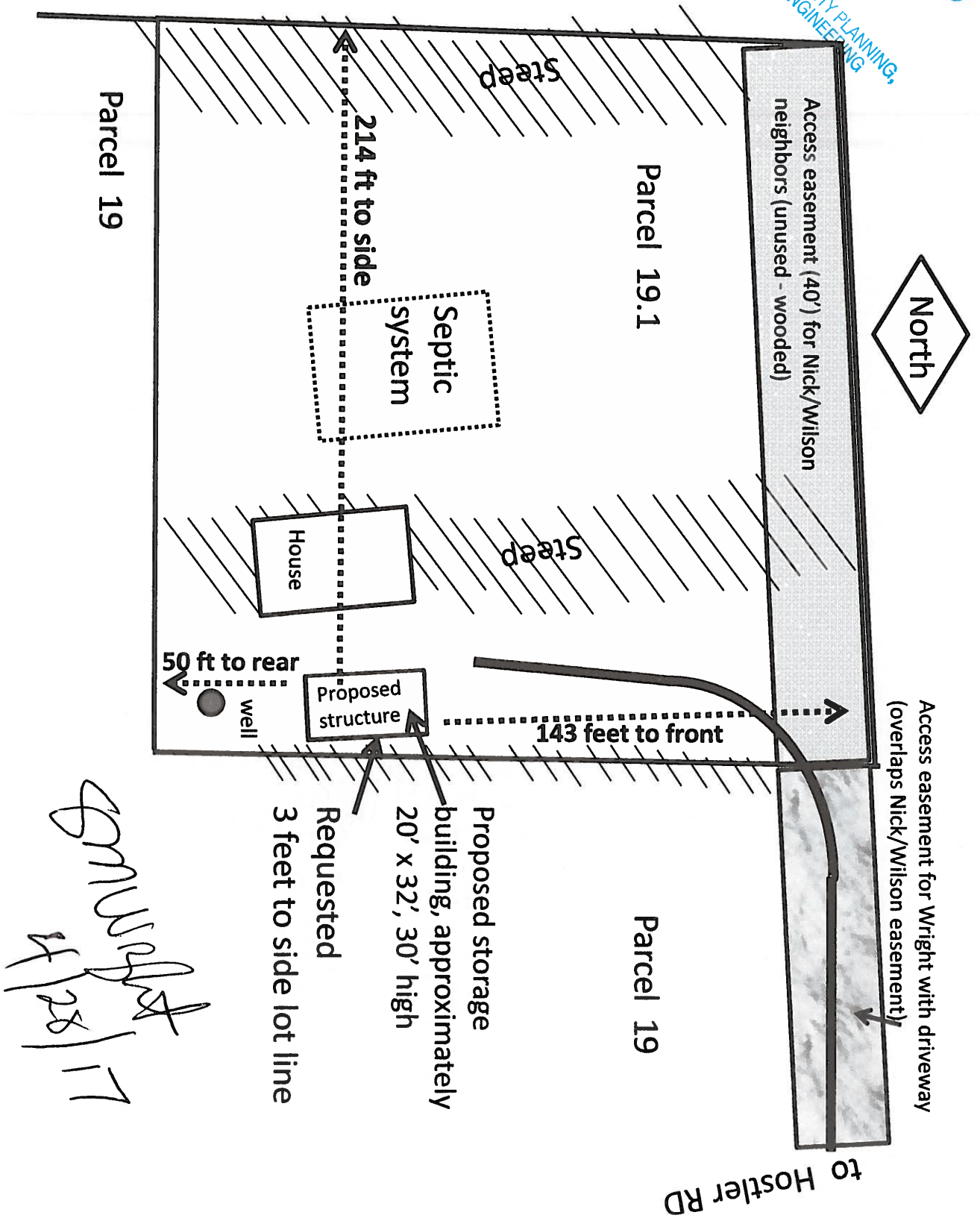

#2117-09

Wright variance request sketch 1 of 2. Dimensions approximate

The location of parcel 19 (also ours) and other features are relevant to the variance request and included here.

Driveway easements: Wright to Wright driveway easement is overlapped by a driveway easement granted to our neighbors to the northwest.

Power Line Right of Way

Wright house site (under construction)

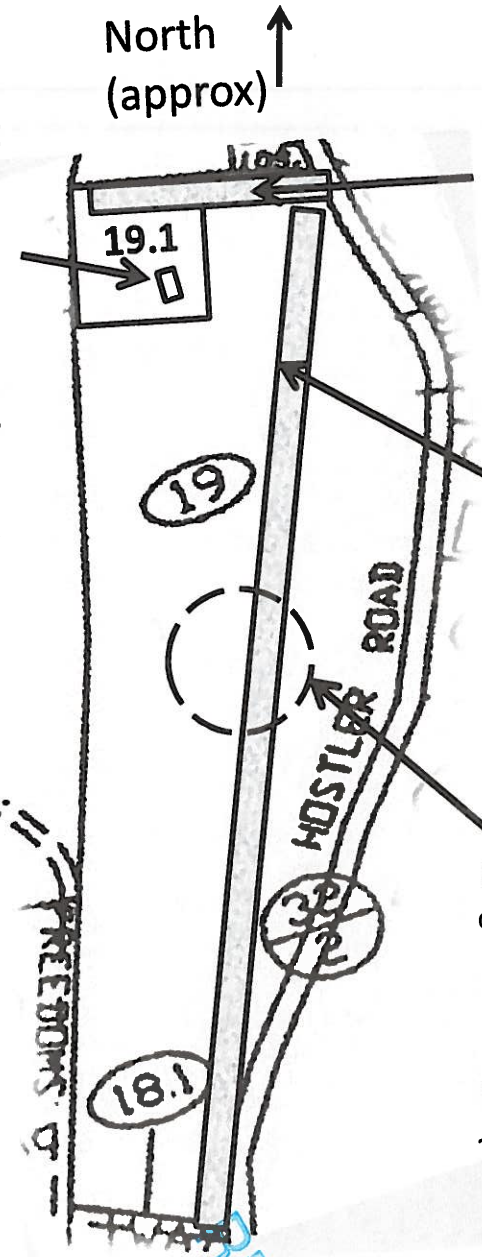

House – See enlarged parcel 19.1 on next page

Jim Wright
4/28/17

RECEIVED
APR 28 2017
JEFFERSON COUNTY PLANNING,
ZONING & ENGINEERING



JEFFERSON COUNTY, WEST VIRGINIA

Office of Planning and Zoning

116 East Washington Street, 2nd Floor

P.O. Box 716

Charles Town, West Virginia 25414

Email: zoning@jeffersoncountywv.org

Phone: (304) 728-3228

Fax: (304) 728-8126

MEMORANDUM

TO: Board of Zoning Appeals Members
CC: Engineering & Building Permits Offices
FROM: Alexandra Beaulieu, Zoning Administrator
DATE: May 19, 2017
SUBJECT: May Zoning Certificate Activity Report

ISSUED ZONING CERTIFICATES

-
- #ZC17-10 SUNNYSIDE LIMITED PARTNERSHIP / OWNER; CONTACT: BARBARA HUYETT
T-MOBILE / CONTACT: MICHAEL WINGARD – APPLICANT
- Issuance Date:* April 25, 2017
Proposed Use: Property contains existing 196.0' self-support Telecommunications Tower. The proposed co-location project consists of T-Mobile installing one (1) backup generator and propane tank on a cement slab.
Physical Location: 844 Wheatland Road; Charles, West Virginia 25414
Zone: Rural
-
- #ZC17-11 TOM LeFEVRE / OWNER
T-MOBILE / CONTACT: DAVID LUTMAN – APPLICANT
- Issuance Date:* April 26, 2017
Proposed Use: Property contains existing 199.0' self-support Telecommunications Tower. T-Mobile to modify the existing wireless installation by installing three (3) new antennas; one (1) 6201 ode cabinet; a PTS 8003 battery support cabinet; six (6) coax cables; relocating one (1) existing antenna & TMA; and removing one (1) existing 2106 cabinet. No height increase to tower, no ground disturbance, no electrical work.
Physical Location: 237 Tel Farm Lane; Kearneysville, West Virginia 25430
Zone: Rural
-
- #ZC17-16 SUSO 2 ALABAMA, LP / CONTACT: PAUL WELLS – OWNER
HAGERSTOWN GOODWILL INDUSTRIES dba HORIZON GOODWILL INDUSTRIES /
CONTACT: DAVID SHUSTER – APPLICANT
- Issuance Date:* April 26, 2017
Proposed Use: Relocate existing Retail Store & Donation Center from Suites 5 & 6 to Suite 1 within the same Shopping Center.
Physical Location: 160 Patrick Henry Way, Suite 1; Charles Town, WV 25414
Zone: Residential-Light Industrial-Commercial
-

#ZC17-19 BLUE RIDGE FIRE UNIT, INC - OWNER
EARL COGLE - APPLICANT

Issuance Date: April 27, 2017

Proposed Use: Commercial kitchen for the purpose of establishing a fundraising operation comprised of preparing, selling and serving pizza and dinners from existing Fire Station Facility. Fundraising operation is an Accessory Use incidental and subordinate to the Principal Permitted Use as a Fire Station.

Physical Location: 181 Keys Gap Road; Harpers Ferry, West Virginia 25425

Zone: Rural

ZC17-20 VINCENT PETTI – OWNER
STEPHEN REYNOLDS – APPLICANT

Issuance Date: May 08, 2017

Proposed Use: Childcare Facility for a maximum of twelve (12) children.

Physical Location: 73 Edmond Road, Unit 4; Kearneysville, WV 25430

Zone: Industrial Commercial

PENDING ZONING CERTIFICATES

#ZC17-05 WV 340 LLC – MICHAEL COLLIER / CONTACT: LINDA LYONS– OWNER
BPIZZA OF WEST VIRGINIA / CONTACT: LEE GARVIN – APPLICANT

Issuance Date: TBD

Proposed Use: Change in Tenant. Pizza Restaurant to include indoor and outdoor (patio) dining and carry-out.

Physical Location: 71 Jefferson Crossing Way, Suite F Charles Town, WV 25414

Zone: Residential- Light Industrial-Commercial

#ZC17-06 PETER S. CORUM – OWNER
CORE MORTGAGE SERVICES, LLC – APPLICANT

Issuance Date: TBD

Proposed Use: Mortgage Services Office

Physical Location: 3988 Kearneysville Pike; Shepherdstown, WV 25443

Zone: Neighborhood Commercial

#ZC17-17 SHENANDOAH PROFESSIONAL CENTER, LLC / DAVID LEONARD, OWNER
JITTISAK PHAKAM– APPLICANT

Issuance Date: TBD

Proposed Use: Change in Tenant. Temporary outdoor BBQ Stand.

Physical Location: 36 Bakerton Road; Harpers Ferry, West Virginia 25425

Zone: Industrial-Commercial

PENDING ZONING CERTIFICATES

#ZC17-18 LOUIS F. (SR.) & ELLEN M. RUFFNER - OWNERS
SUPER NOVELTY, LLC / CONTACT: GREG THROCKMORTON – APPLICANT

Issuance Date: TBD

Proposed Use: Temporary sale of legal fireworks in a 30' x 40' tent with 30' sales trailer and 18' storage trailer. Dates/Times of operation:
June 18, 2017 –July 6, 2017 from 9:00 a.m.-10:00 p.m. daily.
Time-frame of tent removal: No later than July 07, 2017.

Physical Location: 155 Berryville Pike; Rippon, West Virginia 25441

Zone: Industrial-Commercial
